

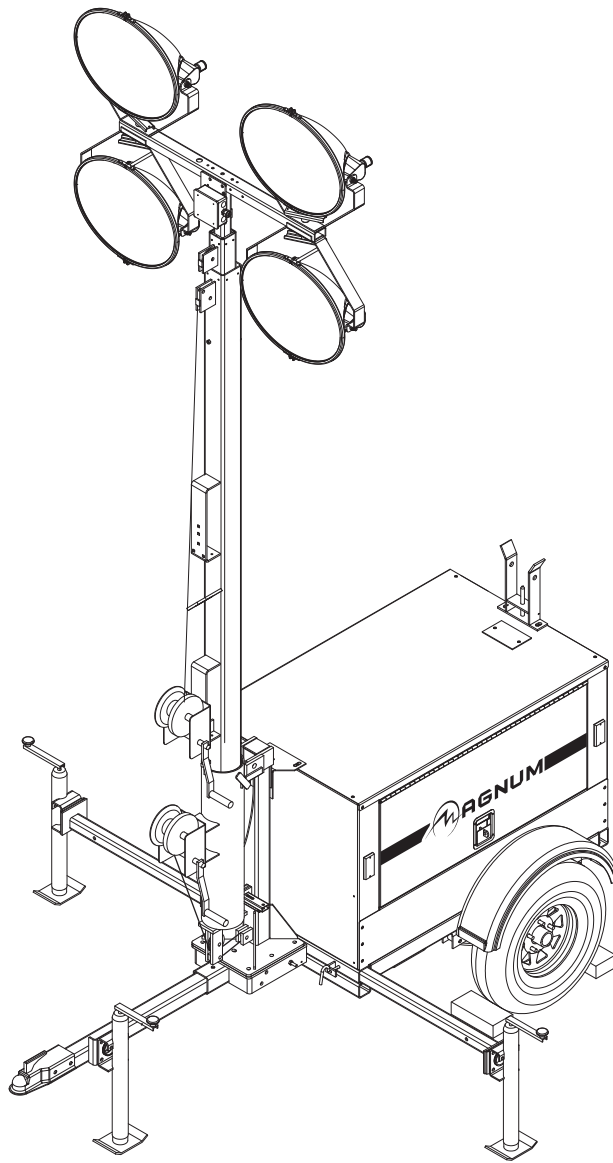

LIGHT TOWER
MLT3060 • MLT3080



OPERATING/PARTS MANUAL

INTRODUCTION

This manual provides information and procedures to safely operate and maintain the engine and generator. For your own safety and protection from physical injury, carefully read, understand and observe the safety instructions described in this manual. *The information contained in this manual was based on machines in production at the time of publication. Magnum Products LLC reserves the right to change any portion of this information without notice.*

DO NOT MODIFY or use this equipment for any application other than which it was designed for.

Magnum Products LLC recommends that a trained and licensed professional perform all electrical wiring and testing functions. Any wiring should be in compliance with the United States National Electric Code (NEC), state and local codes and Occupational Safety and Health Association (OSHA) guidelines.

Keep a copy of this manual with the unit at all times. Additional copies are available from Magnum Products LLC, or can be found at www.m-p-llc.com. An engine operator's manual was also supplied with the unit at the time of shipment from the factory. The manual provides detailed operation and maintenance procedures for the engine. Additional copies of the engine operators manual are available from the engine manufacturer.

MAGNUM PRODUCTS LLC
215 Power Drive • Berlin, WI 54923
U.S.A.
Phone: 920-361-4442
FAX: 920-361-4416
Toll Free: 1-800-926-9768
www.m-p-llc.com

For technical or parts QUESTIONS, please contact Magnum Products' Customer Support or Technical Support team at 920-361-4442 or toll free at 1-800-926-9768. Please have your serial number available.

To ORDER SERVICE PARTS, please contact the dealer from which you purchased the unit, or call Magnum Products to locate a dealer in your area.

Engine Make: _____
Engine Serial Number: _____
Engine Model Number: _____
Generator Make: _____
Generator Model Number: _____
Generator Serial Number: _____
Unit Model Number: _____
Unit Serial Number: _____

▲ WARNING

CALIFORNIA PROPOSITION 65 WARNING: Diesel engine exhaust and some of its constituents are known to the state of California to cause cancer, birth defects and other reproductive harm.

TABLE OF CONTENTS

	Page
INTRODUCTION	2
TABLE OF CONTENTS	3
SAFETY NOTES	4
OPERATING SAFETY	4
ENGINE SAFETY	5
SERVICE SAFETY	5
TOWING SAFETY	6
REPORTING TRAILER SAFETY DEFECTS	6
UNIT SERIAL NUMBER LOCATIONS	7
SAFETY SYMBOL SUMMARY	7
SPECIFICATIONS	8 - 11
LIGHT TOWER SET UP	12
RAISING THE TOWER	13
RAISING THE TOWER WITH THE OPTIONAL ELECTRIC WINCH	14
MAIN CONTROL PANEL COMPONENTS	15
ENGINE STARTING AND OPERATION	16
AUTOMATIC SHUTDOWN	16
LIGHT OPERATION	17
AUXILIARY OUTLETS	17
DERATING FOR ALTITUDE	17
SHUTTING DOWN	18
LOWERING THE TOWER	18
LOWERING THE TOWER EQUIPPED WITH THE OPTIONAL ELECTRIC WINCH	18
REMOVING THE LIGHTS FOR TRANSPORTATION	19
TOWING THE TRAILER	19
LIFTING THE TRAILER	20
DAILY INSPECTION	20
ENGINE MAINTENANCE	21
OPTIONAL LOWER RADIATOR HOSE HEATER USE AND MAINTENANCE	21
TROUBLESHOOTING THE LIGHTS	22
UNIT DECALS	23 - 27
MANUAL WINCH MAST ASSEMBLY	28 - 29
ELECTRIC WINCH MAST ASSEMBLY	30 - 31
FRAME AND COMPONENTS	32 - 33
MAIN ENCLOSURE COMPONENTS	34 - 35
MITSUBISHI ENGINE ASSEMBLY	36 - 37
KUBOTA ENGINE ASSEMBLY	38 - 39
CONTROL PANEL ASSEMBLY	40
CONTROL BOX ASSEMBLY	41
OVAL LIGHT ASSEMBLY	42 - 43
RECTANGULAR LIGHT ASSEMBLY	44 - 45
ROUND LIGHT ASSEMBLY	46 - 47
SPORE RECTANGULAR LIGHT ASSEMBLY	48 - 49
MAST JUNCTION BOX ASSEMBLY - QUICK DISCONNECT LIGHTS	50
MAST JUNCTION BOX ASSEMBLY - HARD WIRED LIGHTS	51
METAL HALIDE BALLAST BOX ASSEMBLY	52
HIGH PRESSURE SODIUM BALLAST BOX ASSEMBLY	53
6 KW GENERATOR ASSEMBLY	54
8 KW GENERATOR ASSEMBLY	55
AC WIRING DIAGRAM - MLT3060	56
AC WIRING DIAGRAM - MLT3080	57
DC WIRING DIAGRAM - MITSUBISHI	58
DC WIRING DIAGRAM - KUBOTA	59 - 60
DC CIRCUIT WIRING DIAGRAM - DUAL ELECTRIC WINCH	61
MAST JUNCTION BOX WIRING	62

SAFETY NOTES



This is the safety alert symbol. It is used to alert you to potential personal injury hazards. Obey all safety messages that follow this symbol to avoid possible injury or death.

This manual contains DANGERS, WARNINGS, CAUTIONS, NOTICES and NOTES which must be followed to prevent the possibility of improper service, damage to the equipment, personal injury or death. The following formatting options will apply when calling the readers attention to the DANGERS, WARNINGS, CAUTIONS, NOTICES and NOTES.

▲ DANGER

INDICATES A HAZARDOUS SITUATION WHICH, IF NOT AVOIDED, WILL RESULT IN DEATH OR SERIOUS INJURY.

▲ WARNING

Indicates a hazardous situation which, if not avoided, could result in death or serious injury.

▲ CAUTION

Indicates a hazardous situation which, if not avoided, may result in minor or moderate injury.

NOTICE

Indicates a hazardous situation which, if not avoided, may result in property or equipment damage.

Note: Notes contain additional information important to a procedure and will be found within the regular text body of this manual.

OPERATING SAFETY



Before using the light tower be sure you read and understand all of the instructions! This equipment was designed for specific applications; DO NOT modify or use this equipment for any application other than which it was designed for. Equipment operated improperly or by untrained personnel can be dangerous! Read the operating instructions and familiarize yourself with the location and proper use of all instruments and controls. Inexperienced operators should receive instruction from someone familiar with the equipment before being allowed to operate or set up the light tower. The following points should be practiced at all times:

- The area immediately surrounding the light tower should be dry, clean, and free of debris.
- Position and operate the light tower on a firm, level surface.
- **NEVER** start a unit in need of repair.
- Lower tower when not in use, or if high winds or electrical storms are expected in the area.
- Make certain light tower is well grounded and securely fastened to a good earthen ground.
- The tower extends up to 30 ft. (9m). Make sure area above trailer is open and clear of overhead wires and obstructions.
- Bulbs become extremely hot in use! Allow bulb and light fixture to cool 10-15 minutes before handling.
- Keep area behind trailer clear of people while raising and lowering mast!
- **NEVER** raise, lower or turn mast while unit is operating!
- Trailer must be leveled and outriggers extended before raising tower. Outriggers must remain extended while tower is up.
- If for any reason any part of mast hangs up or winch cable develops slack while raising or lowering tower, STOP immediately! Contact an authorized service representative.
- **NEVER** remove safety pin or pull mast locking pin while tower is up!

- **NEVER** use tower if insulation on electrical cord is cut or worn through.
- **NEVER** operate lights without protective lens cover in place or with a lens cover that is cracked or damaged!

ENGINE SAFETY



Internal combustion engines present special hazards during operation and fueling! Failure to follow the safety guidelines described below could result in severe injury or death. Also read and follow all safety warnings described in the Engine Operator's Manual. A copy of this manual was supplied with unit when it was shipped from the factory.

- **DO NOT** run engine indoors or in an area with poor ventilation unless exhaust hoses are used. Diesel engine exhaust contains carbon monoxide, a deadly, odorless and colorless gas which, if inhaled, can cause nausea, fainting or death. Make sure engine exhaust cannot seep into closed rooms or ventilation equipment.
- **DO NOT** Operate the unit on a combustible surface.
- **DO NOT** fill fuel tank near an open flame, while smoking, or while engine is running. **DO NOT** fill tank in an enclosed area with poor ventilation.
- **DO NOT** operate with the fuel tank cap loose or missing.
- **DO NOT** touch or lean against hot exhaust pipes or engine cylinders.
- **DO NOT** clean air filter with gasoline or other types of low flash point solvents.
- **DO NOT** remove engine coolant cap while engine is hot.
- **DO NOT** operate the unit without a functional exhaust system. Prolonged exposure to sound levels in excess of 85 DBA can cause permanent hearing loss. Wear hearing protection when working around a running engine.
- Keep area around exhaust pipes and air ducts free of debris to reduce the chance of an accidental fire.
- Batteries contain sulfuric acid which can cause severe injury or death. Sulfuric acid can cause eye damage, burn flesh or eat holes in clothing. Protective eye wear and clothing are necessary when working on or around the battery. Always disconnect the NEGATIVE (-) battery cable from the corresponding terminal before performing any service on the engine or other components.
- Shut the engine down if any of the following conditions exist during operation:
 1. Noticeable change in engine speed.
 2. Loss of electrical output.
 3. Equipment connected to the generator overheats.
 4. Sparking occurs.
 5. Engine misfires or there is excessive engine/generator vibration.
 6. Protective covers are loose or missing.
 7. If the ambient air temperature is above 110° F.

SERVICE SAFETY



This unit uses high voltage circuits capable of causing serious injury or death. Only a qualified electrician should troubleshoot or repair electrical problems occurring in this equipment.

- Before servicing light tower, make sure the engine start switch is turned to OFF, circuit breakers are open (off) and the negative terminal on the battery is disconnected. **NEVER** perform even routine service (oil/filter changes, cleaning, etc.) unless all electrical components are shut down.
- **NEVER** allow water to accumulate around the base of the light tower. If water is present, **DO NOT** service!

- **NEVER** service electrical components if clothing or skin is wet. If the unit is stored outside, check the engine and generator for any moisture and dry the unit before use.
- **NEVER** wash the unit with a power washer or high pressure hose.
- Open main circuit breaker before disconnecting battery cables.
- Keep hands, feet, and loose clothing away from moving parts on generator and engine.
- Make sure slings, chains, hooks, ramps, jacks, and other types of lifting devices are attached securely and have enough weight-bearing capacity to lift or hold the equipment safely. Always remain aware of the position of other people around you when lifting the equipment.

TOWING SAFETY



Towing a trailer requires care! Both the trailer and vehicle must be in good condition and securely fastened to each other to reduce the possibility of an accident. Also, some states require that large trailers be registered and licensed. Contact your local Department of Transportation office to check on license requirements for your particular unit.

- Check that the hitch and coupling on the towing vehicle are rated equal to, or greater than, the trailer's "gross vehicle weight rating" (GVWR).
- Check tires on trailer for tread wear, inflation, and condition.
- Inspect the hitch and coupling for wear or damage. **DO NOT** tow trailer using defective parts!
- Make sure the trailer hitch and the coupling are compatible. Make sure the coupling is securely fastened to the vehicle.
- Connect safety chains in a crossing pattern under the tongue and attach the breakaway cable **TO THE REAR BUMPER OF THE TOWING VEHICLE**. Do not attach the cable to the trailer hitch.
- Make sure directional and brake lights on the trailer are connected and working properly.
- Check that all lug nuts holding wheels on are tight and that none are missing.
- Maximum recommended speed for highway towing is 45 m.p.h. Recommended off-road towing speed is not to exceed 10 m.p.h. or less depending on terrain.

When towing, maintain extra space between vehicles and avoid soft shoulders, curbs and sudden lane changes. If you have not pulled a trailer before, practice turning, stopping, and backing up in an area away from heavy traffic.

A film of grease on the coupler will extend coupler life and eliminate squeaking. Wipe the coupler clean and apply fresh grease each time the trailer is towed.

REPORTING TRAILER SAFETY DEFECTS

If you believe your trailer has a defect which could cause a crash or could cause injury or death, you should immediately inform the National Highway Traffic Safety Administration (NHTSA) in addition to notifying Magnum Products LLC.

If NHTSA receives similar complaints, it may open an investigation; and if it finds that a safety defect exists in a group of vehicles, it may order a recall and remedy campaign. However, NHTSA cannot become involved in individual problem between you, your dealer, or Magnum Products LLC.

To contact NHTSA, you may either call the Auto Safety Hotline toll-free at 1-888-327-4236 (TTY:1-800-424-9153), go to <http://www.safercar.gov>; or write to:

Administrator
NHTSA
1200 New Jersey Avenue S.E.
Washington, DC 20590

You can also obtain other information about motor vehicle safety from <http://www.safercar.gov>.

UNIT SERIAL NUMBER LOCATIONS

Refer to the locations illustrated below to find the unit ID tag, and trailer ID tag on your unit. Important information, such as the unit serial number, model number and Vehicle Identification Number (V.I.N.) for your trailer are found on these tags. Record the information from these tags, so it is available if the tags are lost or damaged. When ordering parts or requesting technical service information, you may be asked to specify this information.

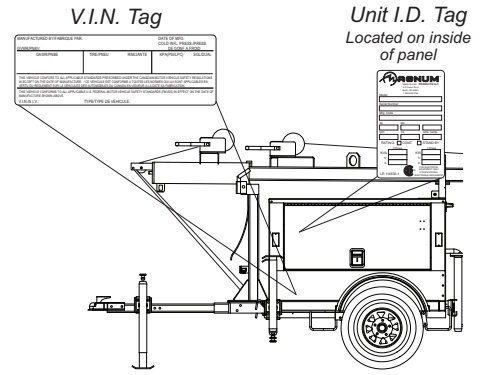

SAFETY SYMBOL SUMMARY

This equipment has been supplied with numerous safety and operating decals. These decals provide important operating instructions and warn of dangers and hazards. Replace any missing or hard-to-read decals and use care when washing or cleaning the unit. Decal placement and part numbers can be found in the beginning of the parts section of this manual. Below is a summary of the intended meanings for the symbols used on the decals.

	Safety alert symbol; Used to alert you to potential personal injury hazards.		Asphyxiation hazard; Operate in well ventilated area.
	Hot surface(s) nearby.		Dangerous voltage may be present.
	Belt/entanglement hazard; Keep body parts clear of this area.		Anchor/tie down point.
	Fan hazard; Keep body parts clear of this area.		Forklift here only.
	Crush hazard; Keep body parts clear of this area.		Use clean diesel fuel only.
	Ultraviolet radiation hazard; Operate only with lens intact.		Burn/scald hazard; pressurized steam.
	Stop engine before fueling.		Read and understand the supplied operator's manual before operating unit.
	Fire/explosion hazard; Keep open flames away from unit.		Unit electrical ground.
	Lift here only.		

SPECIFICATIONS

Read this manual carefully before attempting to use this light tower. The potential for property damage, personal injury or death exists if this equipment is misused or installed incorrectly. Read all of the manuals included with this unit. Each manual details specific information regarding items such as set up, use and service requirements. Specifications are subject to change without notice.

MAGNUM MODEL	MLT3060	MLT3060
Engine		
Make/Brand.....	MITSUBISHI	KUBOTA
Model	L3E-W261ML (end S#081484)	D905-E2BG
	L3E-W461ML (start S#081485)	
Type	Diesel, liquid cooled, 4-stroke	Diesel, liquid cooled, 4-stroke
Horsepower - prime hp (kW)	11.0 (8.2)	10.5 (7.8)
Horsepower - standby hp (kW)	12.2 (9.1)	11.9 (8.9)
Operating Speed rpm	1800	1800
Displacement in³ (L)	57.97 (0.95)	54.92 (.90)
Cylinders - qty	3	3
Fuel Consumption - 100% prime gph (Lph)	0.47 (1.78)	0.50 (1.89)
Battery Type - Group Number	24	24
Battery Voltage (Quantity per Unit)	12V (1)	12V (1)
Battery Rating	440 CCA	440 CCA
Generator		
Make/Brand.....	Marathon Electric	Marathon Electric
Model	201CSA5411	201CSA5411
Type, Insulation	Brushless, F	Brushless, F
Generator Set (Engine/Generator)		
Output kW (kVA)	6.0 (6.0)	6.0 (6.0)
Output Voltage V	120/240, single phase	120/240, single phase
Output Amperes 120V (240V) A	50 (25)	50 (25)
Frequency Hz	60	60
Power Factor	1 (1Ø)	1 (1Ø)
Weights		
Dry Weight lbs (kg)	1640 (744)	1657 (752)
Operating Weight lbs (kg)	1853 (841)	1870 (848)
Capacities		
Fuel Tank Volume gal (L)	30 (114)	30 (114)
Usable Fuel Volume gal (L)	30 (114)	30 (114)
Coolant (incl. engine) qt (L)	4.5 (4.3)	4.8 (4.5)
Oil (incl. filter) qt (L)	3.8 (3.6)	5.4 (5.1)
Maximum Run Time hrs	64	60
AC Distribution		
Circuit Breaker Size	30	30
Voltage Regulation	Capacitor +/-6%	Capacitor +/-6%
Voltages Available 1Ø	120, 240	120, 240

SPECIFICATIONS

Read this manual carefully before attempting to use this light tower. The potential for property damage, personal injury or death exists if this equipment is misused or installed incorrectly. Read all of the manuals included with this unit. Each manual details specific information regarding items such as set up, use and service requirements. Specifications are subject to change without notice.

MAGNUM MODEL

MLT3060

Lighting

Lighting Type.....	Metal Halide
Ballast Type	Coil & Core
Lumens	440,000
Coverage acres (m²)	5 - 7 (20,234 - 28,328)

Dimensions

Length w/ mast stowed in (m)	170 (4.32)
Width in (m)	49 (1.25)
Width w/ outriggers extended in (m)	98 (2.49)
Height w/ mast stowed in (m)	68 (1.73)
Maximum height of tower ft (m)	30 (9.14)

Trailer

Number of Axles	1
Capacity - Axle Rating lbs (kg)	2200 (998)
Tire Size in	13
Hitch - Standard	2" Ball
Maximum Tire Pressure psi	50

SPECIFICATIONS

Read this manual carefully before attempting to use this light tower. The potential for property damage, personal injury or death exists if this equipment is misused or installed incorrectly. Read all of the manuals included with this unit. Each manual details specific information regarding items such as set up, use and service requirements. Specifications are subject to change without notice.

MAGNUM MODEL	MLT3080	MLT3080
Engine		
Make/Brand.....	MITSUBISHI.....	KUBOTA
Model	L3E-W261ML (end S#081484).....	D1105-E3BG
	L3E-W461ML (start S#081485	
Type	Diesel, liquid cooled, 4-stroke	Diesel, liquid cooled, 4-stroke
Horsepower - prime hp (kW)	10.5 (7.8).....	13.5 (10.1)
Horsepower - standby hp (kW)	12.2 (9.1).....	15.4 (11.5)
Operating Speed rpm	1800	1800
Displacement in³ (L)	57.97 (0.95).....	68.53 (1.12)
Cylinders - qty	3	3
Fuel Consumption - 100% prime gph (Lph)	0.63 (2.38).....	0.70
Battery Type - Group Number.....	24	24
Battery Voltage (Quantity per Unit)	12V (1)	12V
Battery Rating	440 CCA.....	440 CCA
Generator		
Make/Brand.....	Marathon Electric	Marathon Electric
Model	332CSA5211	332CSA5211
Type, Insulation	Brushless, F	Brushless, F
Generator Set (Engine/Generator)		
Output kW (kVA)	7.3 (7.3).....	8.0 (8.0)
Output Voltage V	120/240, single phase	120/240, single phase
Output Amperes 120V (240V) A	61 (30).....	66 (33)
Frequency Hz	60	60
Power Factor.....	1 (1Ø).....	1 (1Ø)
Weights		
Dry Weight lbs (kg)	1662 (754).....	1679 (762)
Operating Weight lbs (kg)	1875 (850).....	1892 (859)
Capacities		
Fuel Tank Volume gal (L)	30 (114).....	30 (114)
Usable Fuel Volume gal (L)	30 (114).....	30 (114)
Coolant (incl. engine) qt (L)	4.5 (4.3).....	4.8 (4.5)
Oil (incl. filter) qt (L)	3.8 (3.6).....	5.4 (5.1)
Maximum Run Time hrs	48	43
AC Distribution		
Circuit Breaker Size	40	40
Voltage Regulation	Capacitor +/-6%	Capacitor +/-6%
Voltages Available 1Ø.....	120, 240	120, 240

SPECIFICATIONS

Read this manual carefully before attempting to use this light tower. The potential for property damage, personal injury or death exists if this equipment is misused or installed incorrectly. Read all of the manuals included with this unit. Each manual details specific information regarding items such as set up, use and service requirements. Specifications are subject to change without notice.

MAGNUM MODEL

MLT3080

Lighting

Lighting Type.....	Metal Halide
Ballast Type	Coil & Core
Lumens	440,000
Coverage acres (m²)	5 - 7 (20,234 - 28,328)

Dimensions

Length w/ mast stowed in (m)	170 (4.32)
Width in (m)	49 (1.25)
Width w/ outriggers extended in (m)	98 (2.49)
Height w/ mast stowed in (m)	68 (1.73)
Maximum height of tower ft (m)	30 (9.14)

Trailer

Number of Axles	1
Capacity - Axle Rating lbs (kg)	2200 (998)
Tire Size in	13
Hitch - Standard	2" Ball
Maximum Tire Pressure psi	50

LIGHT TOWER SET UP

1. For maximum light coverage locate tower at ground level or in a spot higher than the area being illuminated by the lamps.

▲ WARNING

The tower extends up to 30 ft (9.14 m). Make sure area above the trailer is open and clear of overhead wires and obstructions.

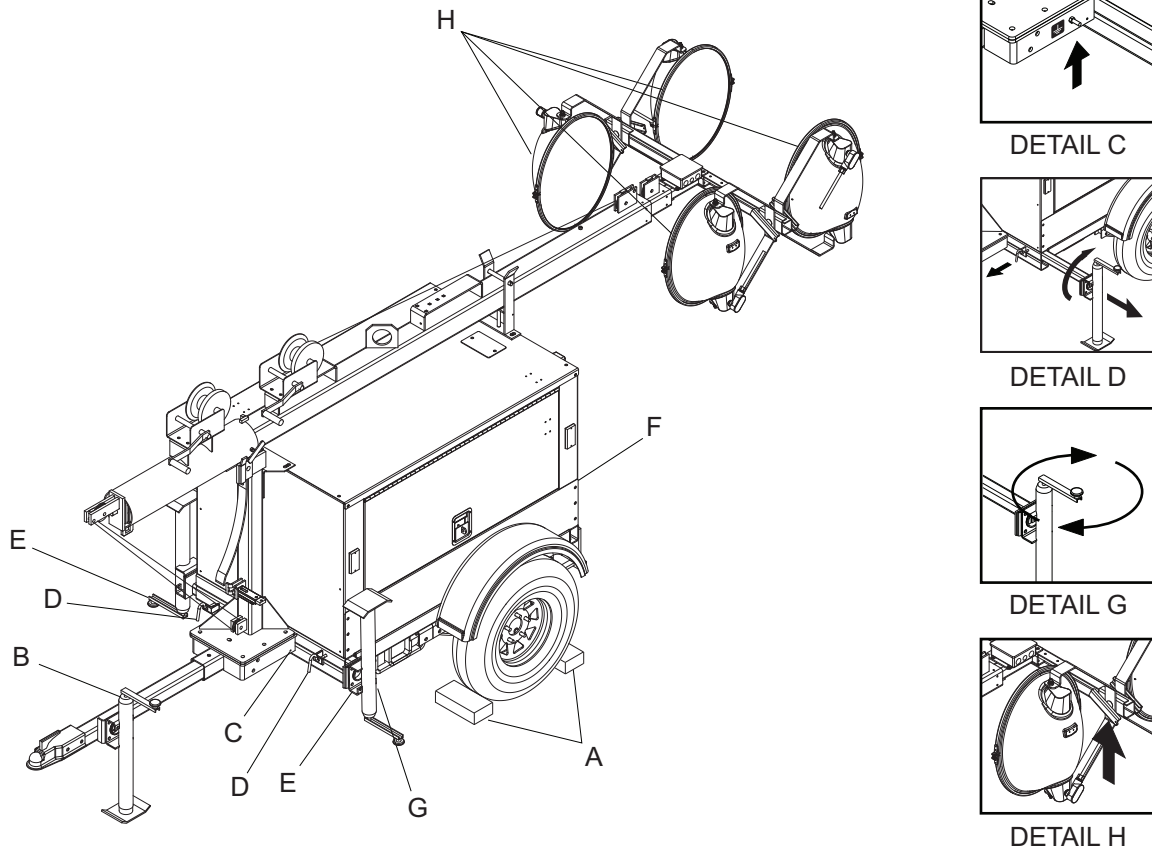

2. Place the trailer on firm ground that is relatively flat. This will make it easier to level the tower. Block the wheels on the trailer to keep it from moving (A).
3. Pull the locking pin on the tongue jack and rotate it 90° until the spring loaded pin snaps back into place (B). Turn the jack handle clockwise to raise the trailer tongue off of the towing vehicle.
4. Connect a good earthen ground to the grounding stud on the frame of the trailer near the trailer tongue (C).
5. Pull the locking pins (D) on the outriggers (E) and pull the outriggers out until the spring loaded locking pin snaps back into place. Pull the locking pin on the outrigger jacks and rotate them 90° so the jack pads are facing down and the spring loaded pin snaps back into place.
6. Pull the locking pin on the rear jack (F) and rotate it 90° until the spring loaded pin snaps back into place. Turn the jack handle clockwise to start leveling the trailer. Adjust all four jacks by turning their handles clockwise until they are firmly in contact with the ground and the trailer is as level as possible (G).
7. Before raising the tower it may be necessary to adjust the lamps. The lamps may be adjusted up, down, left or right by loosening the wing nuts on the trunnion (H) and aiming the lamps in the desired direction. Tighten the hardware completely and make sure the lamps are connected to the junction box.

RAISING THE TOWER

▲ WARNING

The trailer must be leveled with the outriggers extended before raising the tower. The outriggers must remain extended while the tower is up. Failure to level the trailer or extend the outriggers will severely reduce the stability of the unit and could allow the tower to tip and fall.

1. Remove the mast cradle locking pin from the mast cradle (I).
2. Check both sets of mast cables for excessive wear or damage. Make sure the cables are properly centered in each pulley (J). Check the electrical cord for damage.

▲ WARNING

Do not start the unit if the insulation on the electrical cord is cut or worn through. Bare wires in contact with the mast or frame may energize the trailer and cause electrocution. Repair or replace cord.

3. Make sure the area behind the unit is clear before raising the mast to the vertical position.
4. Remove the safety pin (K) from the mast lock bar (L). Using the handle for the lower mast winch (M), raise the mast until it is vertical and the tab on the mast is positioned into the mast lock. The mast lock bar should snap into place automatically. Secure the lock with the safety pin (N).
5. After the mast is up and locked into place, use the upper mast winch (O) to telescope the tower to the desired height. Extend the mast slowly, making sure that the electrical cord is extending at the top sections of the mast. If, for any reason, the winch cable begins to develop slack or any of the tower sections get stuck, STOP IMMEDIATELY and contact an authorized service center.

▲ CAUTION

Do not extend the mast beyond the colored mark on the middle mast tube (P).

6. The mast can be rotated by loosening the locking knob at the bottom of the mast (Q). Turn the mast until the lights face in the desired direction and then tighten the knob.

▲ WARNING

Never raise or lower the mast while the unit is operating!
Never remove the safety pin or mast lock while the tower is up.
Releasing the lock will cause the mast to fall.

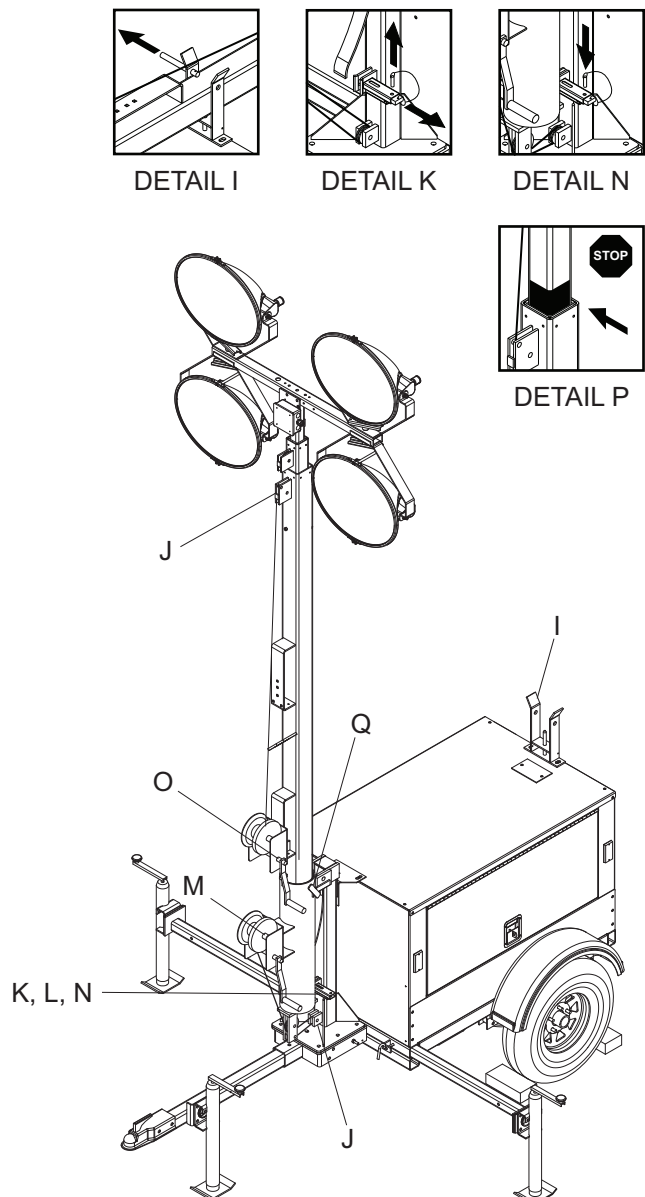

RAISING THE TOWER WITH THE OPTIONAL ELECTRIC WINCH

1. Set up and level the trailer as described on page 12, and follow steps 1-3 on page 13.
2. Remove the safety pin from the mast lock bar (R).
3. Press the lower winch control toggle switch upward to raise mast into the vertical position (S). Hold switch until the mast lock is engaged. The mast lock bar should snap into place automatically. **Note:** On light towers equipped with the electric winch option, a limit switch on the mast tube will disconnect power to the lower electric winch to prevent deadheading the winch.
4. Secure the lock with the safety pin (T).
5. Press and hold the upper winch control toggle switch upward to telescope the mast to desired height (U). Extend the mast slowly, making sure that the coiled electrical cord is extending at the top sections of the mast. If, for any reason, the winch cable begins to develop slack or any of the tower sections get stuck, STOP IMMEDIATELY and contact an authorized servicecenter.

⚠ CAUTION

Do not extend the mast beyond the colored mark on top of the lower mast section (V). On light towers equipped with the electric winch option, a limit switch on the main mast section will disconnect power to the upper electric winch to prevent over extending the mast.

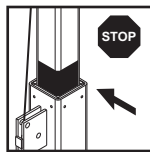

DETAIL V

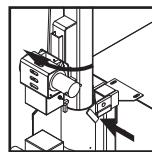

DETAIL W

6. The mast can be rotated by loosening the locking knob at the bottom of the mast (W). Turn the mast until the lights face in the desired direction and then tighten the knob.

⚠ WARNING

Never raise or lower the mast while the unit is operating!
Never remove the safety pin or mast lock while the tower is up.
Releasing the lock will cause the mast to fall.

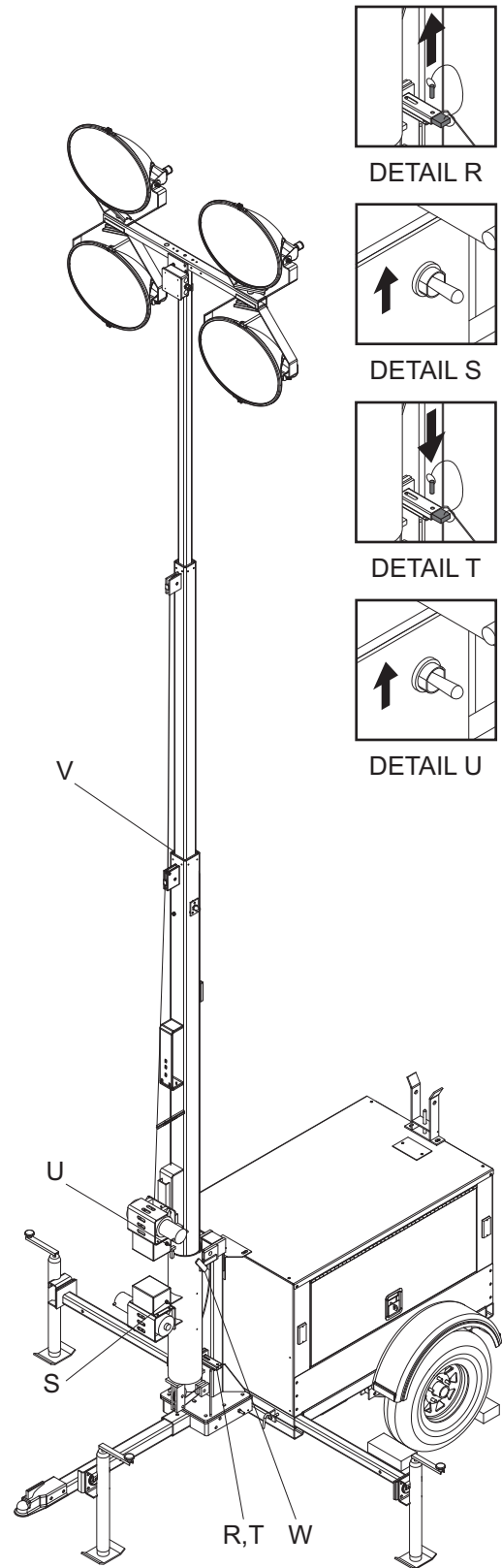

MAIN CONTROL PANEL COMPONENTS

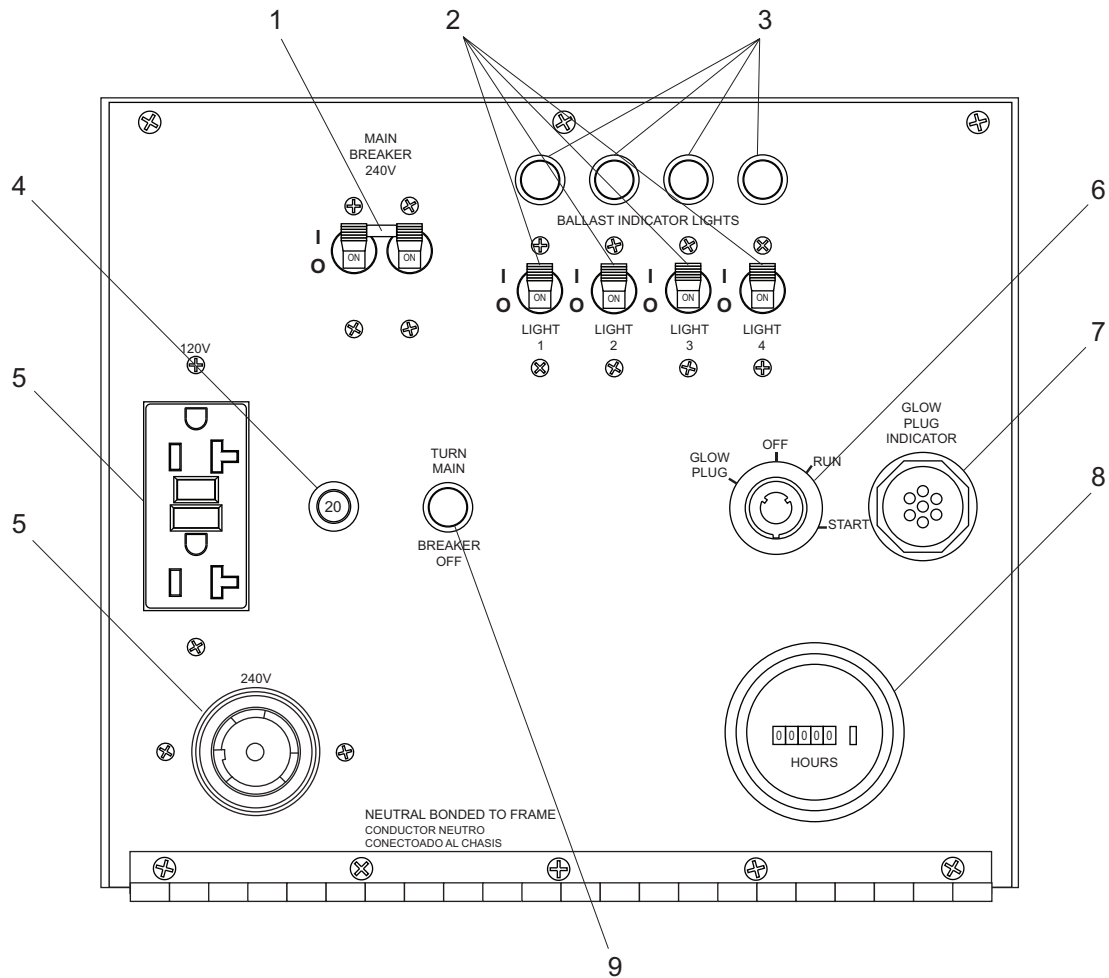

1. **MAIN CIRCUIT BREAKER (30A or 40A):** This breaker will disconnect power to the lights and auxiliary outlets. It will also disable the starting circuit if engine starting is attempted when the main breaker is on.
2. **INDIVIDUAL CIRCUIT BREAKERS:** One breaker is supplied for each light.
3. **BALLAST INDICATOR LIGHTS:** Indicates power from the ballast to each light.
4. **OUTLET CIRCUIT BREAKER:** This breaker is supplied for the standard 120V GFCI outlet.
5. **AUXILIARY OUTLETS:** These outlets supply power for accessories connected to the generator when the engine is running and the main circuit breaker is switched to the on "I" position.
6. **ENGINE STARTING SWITCH:** Keyed switch operates glow plugs, starts and stops engine.
7. **ENGINE GLOW PLUG INDICATOR:** Indicates operation of the engine glow plugs on certain engines.
8. **ENGINE HOUR METER:** Keeps track of engine hours for service.
9. **CIRCUIT BREAKER INDICATOR LIGHT:** This light indicates that the main circuit breaker must be opened (switched off) before starting the engine.

ENGINE STARTING AND OPERATION

1. Check engine oil, fuel and coolant levels. **Note:** *If the engine was run out of fuel or the fuel tank was drained, it may be necessary to bleed the fuel lines. Refer to the engine operation manual supplied with the unit.*
2. Check the condition of the electrical cord on the inside of the unit.

▲ WARNING

Do not start the unit if the insulation on the electrical cord is cut or worn through. Bare wires in contact with the mast or frame may energize the trailer and cause electrocution. Repair or replace cord.

3. Check that the main circuit breaker and individual circuit breakers for each of the lights are in the off "O" position. **Note:** *If the red light on the control panel "TURN MAIN BREAKER OFF" is illuminated when the key is turned to the "START" position, the breaker is closed (switched on).*

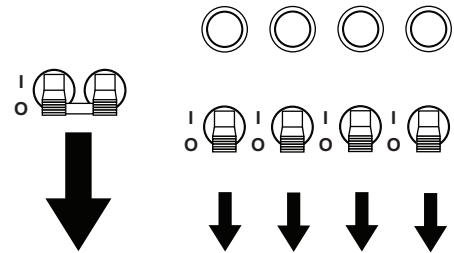

▲ WARNING

NEVER START THE ENGINE WITH ANY OF THE CIRCUIT BREAKERS SWITCHED ON!
Any load on the generator during start up will cause severe damage or destroy the generator!

4. Turn the key on the engine start switch to the left "GLOW PLUG" position and hold the key in place until the glow plug indicator turns red. As soon as it's glowing turn the key to the right to the "START" position and hold it until the engine cranks and starts running. Release the key, it will move to the "RUN" position.

ACTIVATE GLOW PLUGS

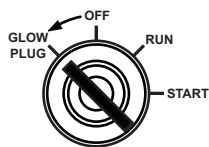

CRANK ENGINE TO START

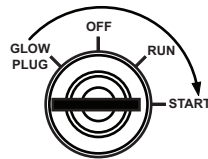

RELEASE KEY

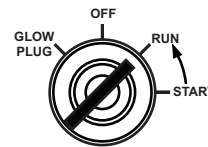

NOTICE

Do not crank the engine longer than 10 seconds at a time. If the engine will not start, wait 30 seconds to allow the starter motor to cool and then repeat the starting procedure. Excessive cranking will cause damage to the starter.

5. **Note:** *If oil pressure is not obtained within 30 seconds after the key is switched to the "RUN" position, the low-oil automatic shutdown will turn off the fuel supply, stopping the engine. Check the oil level and turn the key to the "OFF" position to reset the oil pressure timer before attempting to restart the engine.*
6. Once the engine is running, allow it to reach normal operating temperature before switching on any loads.

AUTOMATIC SHUTDOWN

This unit is equipped with a low oil pressure and high coolant temperature auto-shutdown system. This system will automatically shut off the fuel supply to stop the engine if oil pressure drops too low or the engine exceeds normal operating temperature. Return the switch to the "OFF" position to reset the unit after you have determined the cause of the shutdown.

LIGHT OPERATION

- Once the engine is up to temperature and running smoothly, switch main circuit breaker (1) to the ON "I" position.
- With main circuit breaker on, switch each individual circuit breaker for the lights (2) to ON "I", one at a time.
- The ballast indicator lights (3) will come on momentarily as the lights strike. As the lights warm up, the ballast indicator lights will continue to get brighter and then remain on. This confirms that power is coming from the ballasts to the lights.
- If an indicator light does not come on, the ballast may need to be serviced. If the indicator light comes on and stays lit but the related light is not illuminated, check the bulb or the mast wiring.
- The lights require a warm up period of 5-15 minutes before they reach full output. If the lights are shut down, they require a cool-down period of approximately 10 minutes before they can be switched on again.
- The light tower uses four 1000W bulbs. When checking or replacing the bulbs, wipe them with a clean cloth to avoid leaving any grease, oil residue or fingerprints on the glass. Any residue can create a hot spot on the bulb, causing premature bulb failure.

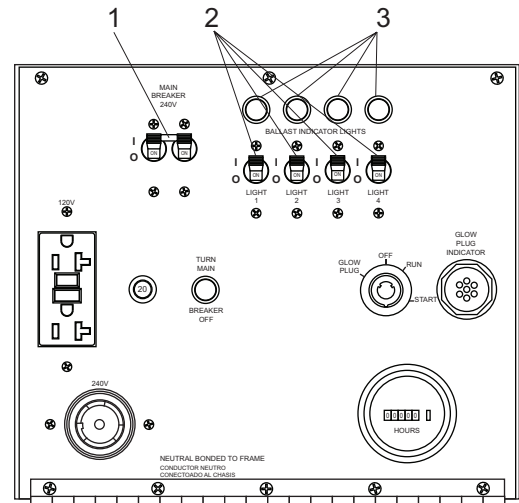

▲ WARNING

NEVER OPERATE THE LIGHTS WITHOUT THE PROTECTIVE LENS COVER OR WITH A LENS COVER THAT IS CRACKED OR DAMAGED! The bulbs in the light fixtures produce high temperatures and operate under pressure. A broken or missing lens cover could cause the bulbs to shatter, causing injury.

▲ WARNING

Bulbs become extremely hot in use! Allow bulb fixture to cool 10-15 minutes before handling.

AUXILIARY OUTLETS

The control panel is equipped with two outlets for running accessories or tools from the generator. Power is supplied to the outlets any time the engine is running and the main circuit breaker is switched on "I". **Note: Do not pull more than 1000W from each outlet when the lights are on.** This will overload the generator and cause the main circuit breaker to trip. Should the breaker trip, switch off the lights, remove some of the load to the outlets and wait 10 minutes for the bulbs to cool before turning them back on.

With all of the lights off, the full generator output may be used with the 240V twist-lock outlet.

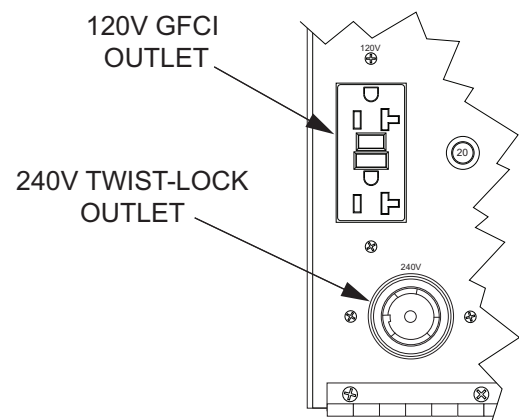

DERATING FOR ALTITUDE

All light towers are subject to derating for altitude and temperature. Although derating should not affect the operation of the lights, it will reduce the available power for operating tools and accessories connected to the auxiliary outlets. Typical reductions in performance are 2-4% for every 1000 ft. (305 m) of elevation and 1% per 10° F (3-5° C) increase in ambient air temperature over 72° F (22.2° C).

SHUTTING DOWN

When you have finished using the light tower proceed with shut down as follows:

1. Remove any loads from the auxiliary outlets.
2. Switch the individual circuit breakers for each light to the OFF "O" position.
3. Switch the main circuit breaker to the OFF "O" position.
4. Turn the ENGINE START SWITCH to the OFF position.

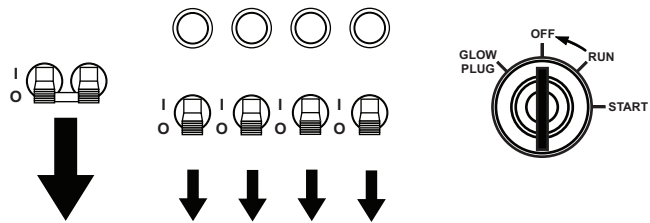

LOWERING THE TOWER

1. Shut down the lights and engine. Allow the lights to cool 10-15 minutes before lowering the tower.
2. Turn the upper mast winch handle to collapse the tower to its lowest position. Make sure the electrical cord returns to the storage tube properly.

▲ WARNING

If the mast hangs up or the winch cable begins to develop slack, STOP IMMEDIATELY! Excess slack in the cable could cause the mast to collapse should it free up without warning. Contact an authorized service center.

3. Loosen the mast rotation knob and rotate the tower so the mast mounted winches face the front of the unit. The white alignment arrow points should line up on the mast sections and the metal stop tabs should be touching. Tighten the mast rotation knob.
4. Release the mast lock by pulling the safety pin on the mast lock and pulling the lock free. Turn the handle of the lower mast winch until the mast spring begins to pivot the tower down. Release the mast lock and continue to lower the tower until it rests in the cradle. **Note:** *If the mast lock does not pull free, operate lower winch slightly to relieve pressure on the mast lock.*
5. After the mast is completely down, insert the cradle lock pin and secure it with the safety pin.
6. Position lights to aim at the ground. If the trailer is going to be moved, Magnum Products LLC strongly recommends that the lights be removed from the mast and stowed for transportation. See REMOVING THE LIGHTS FOR TRANSPORTATION section on page 19.

LOWERING THE TOWER EQUIPPED WITH THE OPTIONAL ELECTRIC WINCH

1. Shut down the lights and engine. Allow the lights to cool 10-15 minutes before lowering the tower.
2. Loosen the mast rotation knob and rotate the tower so the mast mounted winches face the front of the unit. The white alignment arrow points should line up on the mast sections and the metal stop tabs should be touching. Tighten the mast rotation knob.
3. Press and hold the upper winch control toggle switch downward to collapse the mast to its lowest level. Make sure the coiled electrical cord on the top sections of the mast does not get tangled on the mast sections. **Note:** *Some electric winch models are equipped with an anti-backlash safety limit switch. This switch will disconnect power to the winch if excess cable slack is detected, preventing accidental lowering of the tower. If, for any reason, the cable begins to develop slack or any of the tower sections get stuck, STOP IMMEDIATELY and contact an authorized service center.*

4. Release the mast lock bar by pulling the safety pin on the mast lock and pulling the lock bar free. Lower the mast by holding the lower winch control toggle switch to the right until the mast is resting in the transport cradle. **Note:** *If the lock bar does not pull free, activate lower winch slightly to relieve pressure on the mast lock bar.*
5. After the mast is completely down, insert the cradle lock pin and secure it with the safety pin.
6. Position lights to aim at the ground. If the trailer is going to be moved, Magnum Products LLC strongly recommends that the lights be removed from the mast and stowed for transportation.

REMOVING THE LIGHTS FOR TRANSPORTATION

1. On units equipped with quick disconnect fittings for the lights, disconnect the power cords from the junction box at the top of the mast. Replace the dust caps on the junction box. On other units, remove the junction box cover on the top of the mast and disconnect **ONLY** the mast light wires from the terminal blocks. To release the wires from the terminal blocks, flip the locking levers down and pull out the appropriate wires (A).
2. Remove the lights by removing the wing nut that holds the light fixture bracket to the cross tube. Attach the lights to the storage brackets (if equipped) located on the mast tube on either side of the central lifting eye.

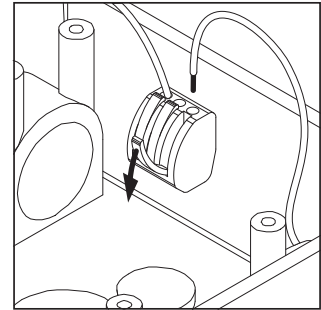

TOWING THE TRAILER

Once the engine is shut down and the mast and lights are properly stowed, the trailer can be made ready for transport.

1. Raise the rear jack completely and release the locking pin to rotate it up into the travel position. Make sure the locking pin snaps into place.
2. Raise the outrigger jacks completely and release the jack locking pin to swing the jacks up into the travel position. Make sure the locking pins snap into place. Release the outrigger locking pins and slide the outriggers into the trailer frame until the locking pins snap into place.
3. Use the drawbar jack to raise or lower the trailer onto the hitch of the towing vehicle. Lock the hitch coupling and attach the safety chains or cables to the vehicle. Release the jack locking pin and rotate the jack into the travel position. Make sure the locking pin snaps into place.
4. To ensure proper operation of the jacks, lube the grease fittings located on the leveling jacks.
5. Connect any trailer wiring to the tow vehicle. Check for proper operation of the stop and signal lights.
6. Make sure the cradle locking pin is in place.
7. Make sure the doors are properly latched.
8. If the trailer is going to be driven over rough ground, remove the bulbs from the light fixtures.
9. Check for proper inflation of the trailer tires. The maximum tire inflation is 50 psi.
10. Attach a red flag to the end of the mast before towing.
11. Maximum recommended speed for highway towing is 45 mph. Recommended off-road towing speed is not to exceed 10 mph or less depending on terrain.

LIFTING THE TRAILER

When lifting the light tower and trailer, attach any slings, chains or hooks directly to the central lifting eye. The lifting eye is located on the mast between the two forklift pockets.

1. Make sure the equipment being used to lift the light tower has sufficient capacity. **Note:** See the unit specifications beginning on page 9 for approximate weights.
2. Make sure the cradle locking pin is in place.
3. Always remain aware of the position of other people and objects around you as you move the unit.
4. Use the upper or lower forklift pockets with care. Approach the unit as perpendicular as possible to avoid any damage to the unit. Make sure the mast winch handles or any other obstructions are clear of the forklift tines before lifting.

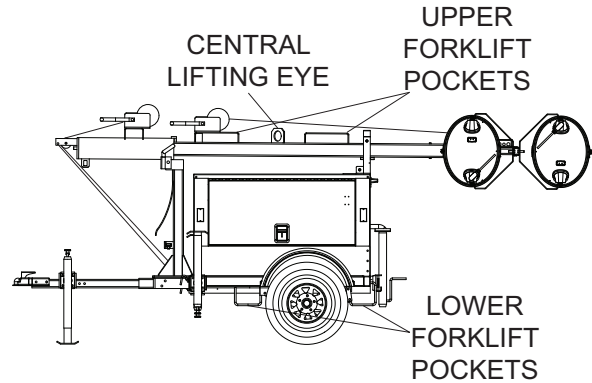

DAILY INSPECTION

1. Inspect condition of electrical cords. **DO NOT** use light tower if insulation is cut or worn through.
2. Check that winch cables are in good condition and that they are centered on each pulley. **DO NOT** use a cable that is kinked or starting to unravel.

PROPER MAST CABLE ROUTING

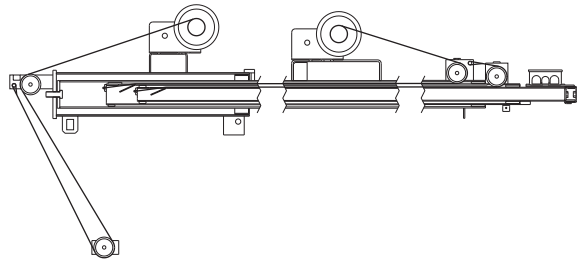

3. Check that the safety pins for the mast lock rod and mast lock bar are present and secured with a chain. Check that the spring located in the mast lock bar is not broken or missing. Check the operation of the mast lock bar.
4. Check the fuel, oil and coolant levels.
5. Check the wheel lugs. Tighten or replace any that are loose or missing. If a tire has been removed for axle service or replaced, tighten the lugs in the order shown, to the following specifications:
 - A. Start all lug nuts by hand.
 - B. First pass tighten to 20-25 Ft-Lbs (27-33 Nm).
 - C. Second pass tighten to 50-60 Ft-Lbs (67-81 Nm).
 - D. Third pass tighten to 90-120 Ft-Lbs (122-162 Nm).

After the first road use, retorque the lug nuts in sequence.

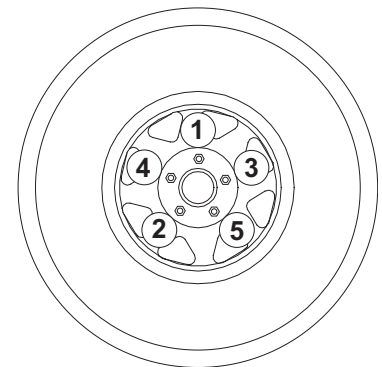

ENGINE MAINTENANCE

The periodic maintenance schedule below lists basic maintenance intervals for the engine. For detailed maintenance procedures refer to the engine operators manual. A copy of this manual was supplied with the unit when it was shipped from the factory. For additional or replacement copies of the engine operators manual, contact an authorized engine dealer in your area.

	Check Daily	Every 50 Hours	Every 250 Hours	Every 500 Hours	Every 1000 Hours	Every 2 Years
Check Tire Pressures	■					
Check Engine Oil Level	■					
Check Engine Coolant Level	■					
Check Fuel Level	■					
Check Alternator Belt	■					
Drain Fuel Filter*		■				
Check Radiator Hoses		■				
Change Engine Oil & Filter**		■	■			
Check All Electrical Connections			■			
Check For Fuel Leaks			■			
Replace Fuel Filter Element			■			
Inspect and Clean Radiator Fins				■		
Lubricate Leveling Jacks				■		
Clean Air Filter Element, replace if necessary				■		
Replace Alternator Belt				■		
Inspect Engine Starting Battery					■	
Check Valve Clearance						■
Drain and Clean Fuel Tank						■
Change Engine Coolant						■
Replace Radiator Hoses						■

*Drain daily in humid or rainy conditions.

**Change the engine oil and filter after the first 50 hours of operation, then every 250 hours.

OPTIONAL LOWER RADIATOR HOSE HEATER USE AND MAINTENANCE

The following points should be followed when operating a unit equipped with a lower radiator hose heater.

▲ WARNING

Improper use of the lower radiator hose heater could result in serious personal injury.

- Ensure cooling system is full of proper mixture of water and engine coolant before each heater use.
- Heater is designed for all-night operation; however, 2-5 hours of heating just prior to starting is usually sufficient for proper engine starting.
- When heater is in operation, unit must be parked in a level position to maintain the proper orientation of the heater.
- Use only an undamaged extension cord, outdoors rated, three-prong grounded 120VAC cord with a minimum amperage rating of 10A. Connect to properly grounded 120VAC, GFCI outlet only.
- Unplug extension cord from power first; then unplug heater cordset from extension cord before starting the engine.

TROUBLESHOOTING THE LIGHTS

▲ WARNING

HIGH VOLTAGE! THIS UNIT USES HIGH VOLTAGE CIRCUITS CAPABLE OF CAUSING SERIOUS INJURY OR DEATH. ONLY A QUALIFIED ELECTRICIAN SHOULD TROUBLESHOOT OR REPAIR ELECTRICAL PROBLEMS OCCURRING IN THIS EQUIPMENT.

MAST LIGHTS OFF BUT BALLAST INDICATORS ON CONTROL PANEL ARE ON:

1. Mast light is too hot. Allow light to cool 10-15 minutes before restarting.
2. Faulty bulb connection. Check that the bulb is tight in the socket.
3. Bulb broken. Check for broken arc tube or outer bulb jacket, broken or loose components in bulb envelope or blackening/deposits inside tube.
4. Check the connections inside the mast junction box and each mast light housing/socket.
5. Check the mast electrical cord for damage and check the cord connections inside the control box.

MAST LIGHTS OFF AND BALLAST INDICATORS ON CONTROL PANEL ARE OFF:

1. Check the connections inside the control box and inside each ballast box.
2. Generator output incorrect. Check the incoming voltage to the ballast by checking the available voltage on the duplex receptacle. Incoming voltage should be 120V +/- 5V. If voltage is incorrect engine speed may need to be adjusted or generator may require service. Contact Magnum Products Technical Service Department for more information.
3. Low transformer output. The voltage from the transformer should read approximately 400 VAC as the light "strikes" (induces an arc), then drop and slowly rise back up to stabilize at 240-260 VAC. On quick disconnect models, measure across the junction box terminals when the light is unplugged. On hard wired models, remove the mast junction box cover and insert the wire probes into the connector blocks for the lights and ground. If proper voltage is not achieved, perform capacitor check to determine if the capacitor or coil needs to be replaced.

MAST LIGHTS ON BUT THE LIGHT OUTPUT IS LOW:

1. Fixture or lens dirty. Clean reflective surface inside fixture and both inside and outside surface of glass lens.
2. Bulb worn. Replace bulb due to normal use.
3. Check the mast coil cord, mast junction box and mast light connections.
4. Generator output incorrect. Check the incoming voltage to the ballast. Incoming voltage should be 120V +/- 5V. If voltage is incorrect engine speed may need to be adjusted or generator may require service.
5. Low transformer output. Perform transformer check as described above.

If problems persist, contact Magnum Products Technical Service for assistance.

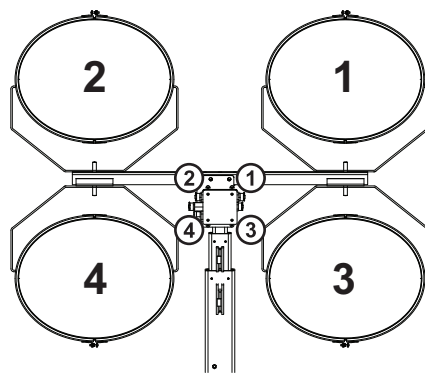

MAST LIGHT CONNECTIONS

UNIT DECALS

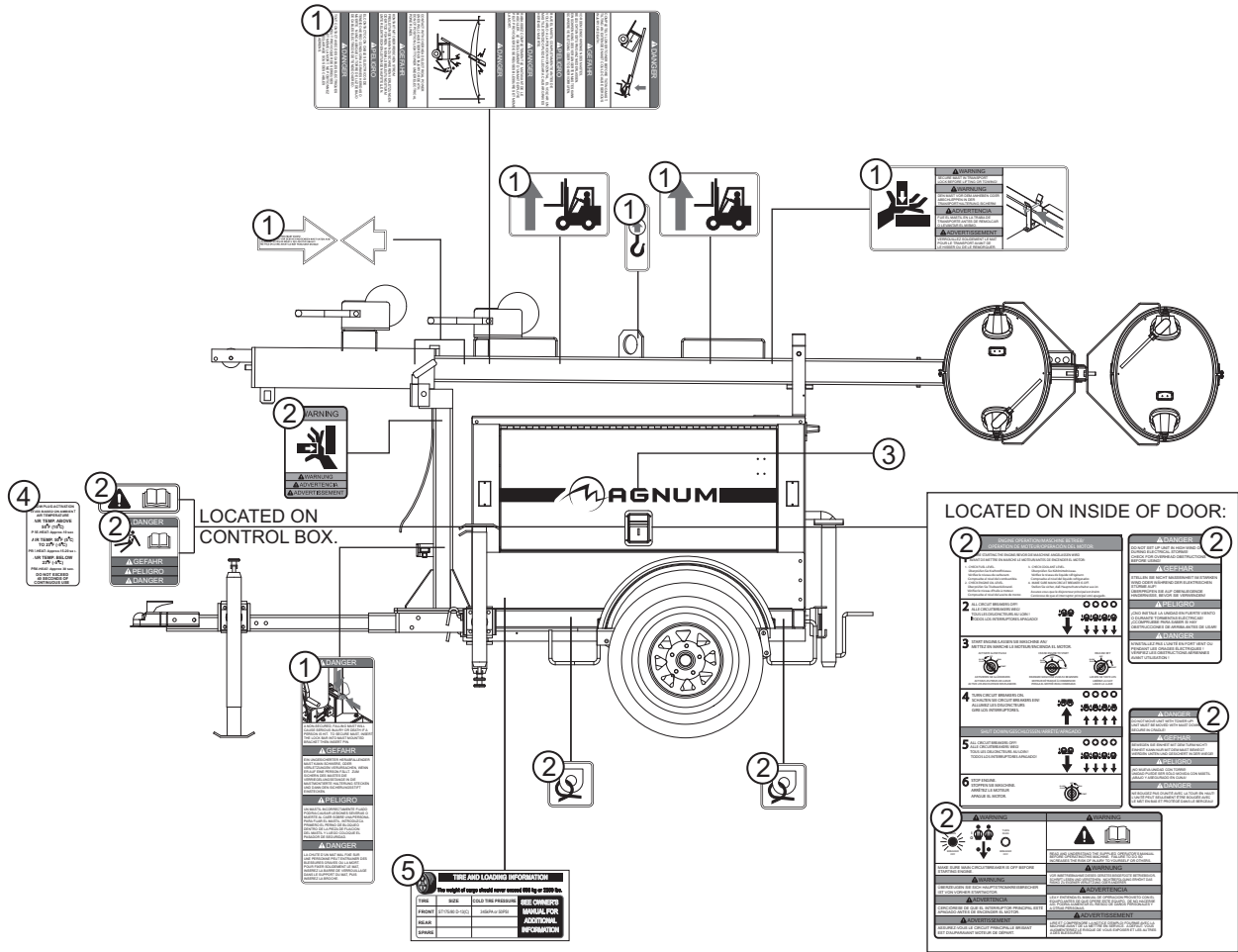

ITEM	PART	QTY	DESCRIPTION	NOTES
1	12140	1	Decal set, common mast 4-lang.	
2	12141	1	Decal set, engine/electrical safety 4-lang.	
3	11174	1	Decal, Magnum logo with red stripe	
4	12405	1	Decal, glow plug operation	For Kubota units only
5	29009	1	Decal, tire and loading information	

UNIT DECALS

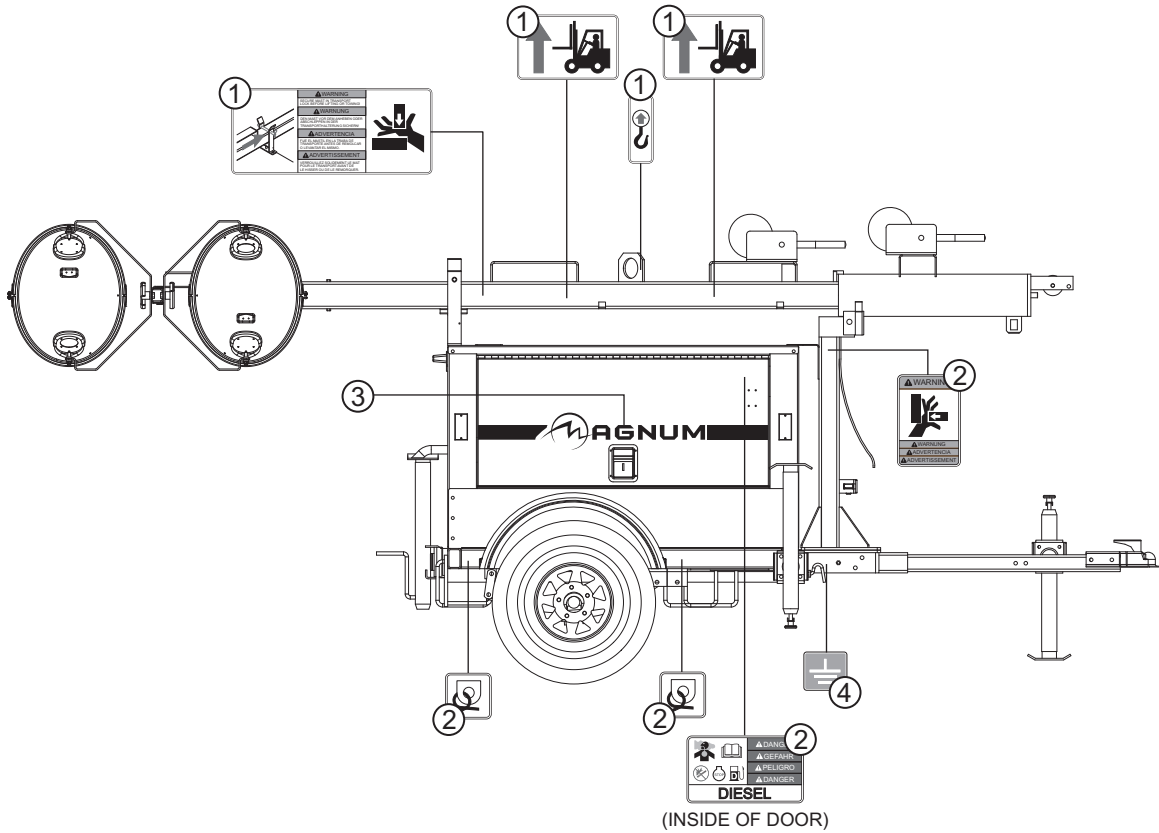

ITEM	PART	QTY	DESCRIPTION	NOTES
1	12140	1	Decal set, common mast 4-lang.	
2	12141	1	Decal set, engine/electrical safety 4-lang.	
3	11174	1	Decal, Magnum logo with red stripe	
4	12142	1	Decal, ground	

UNIT DECALS

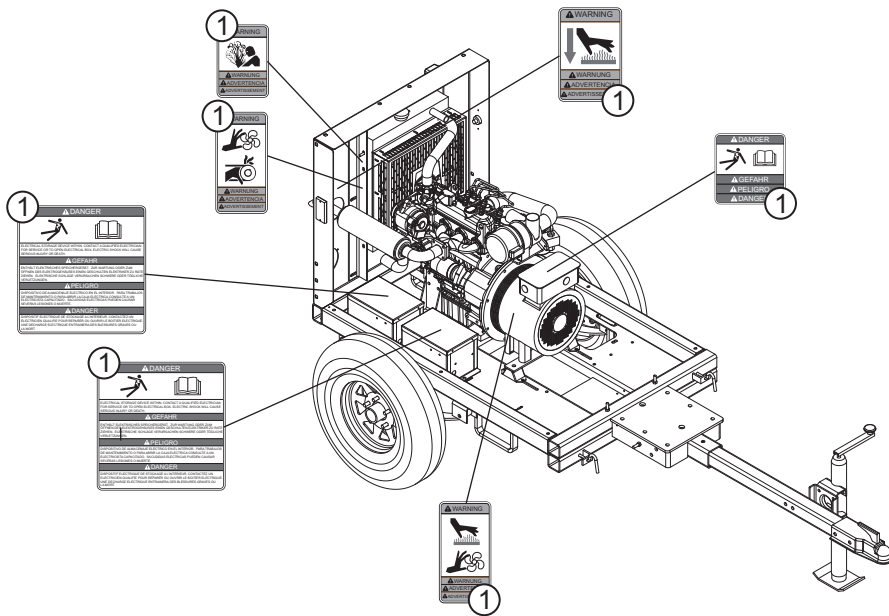
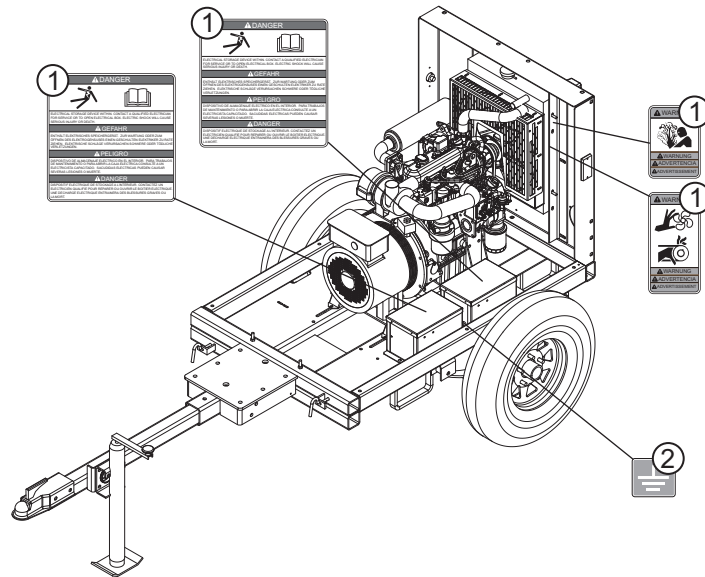

ITEM	PART	QTY	DESCRIPTION	NOTES
1	12141	1	Decal set, engine/electrical safety 4-lang.	
2	12142	1	Decal, ground	

UNIT DECALS

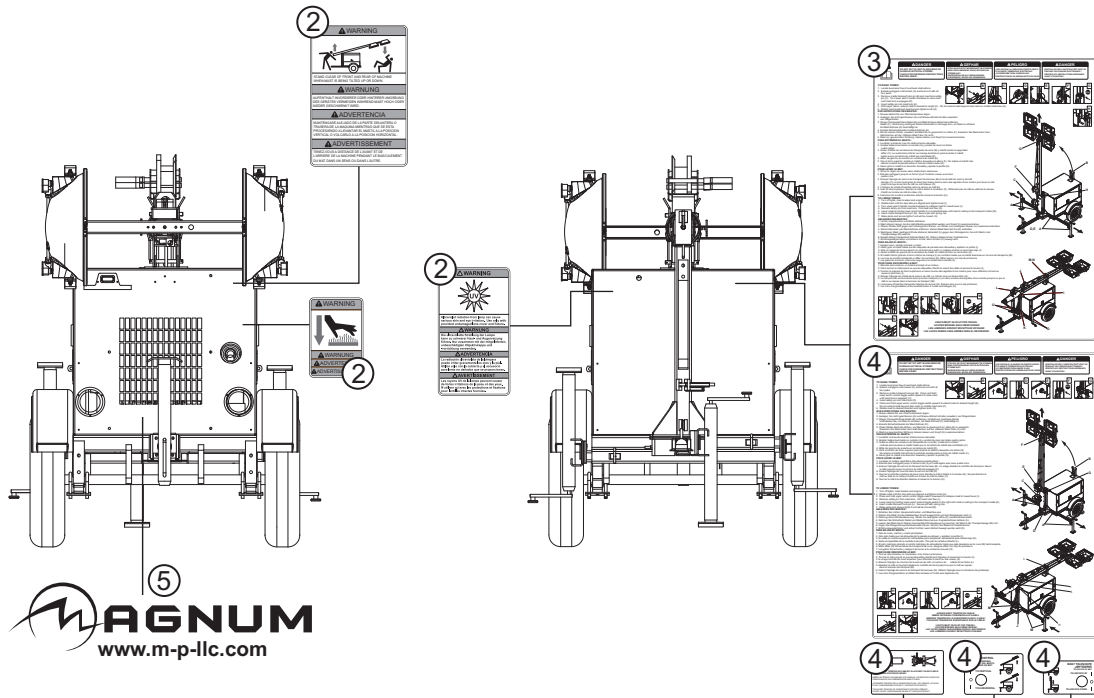

LOCATED ON
ELECTRIC WINCHES

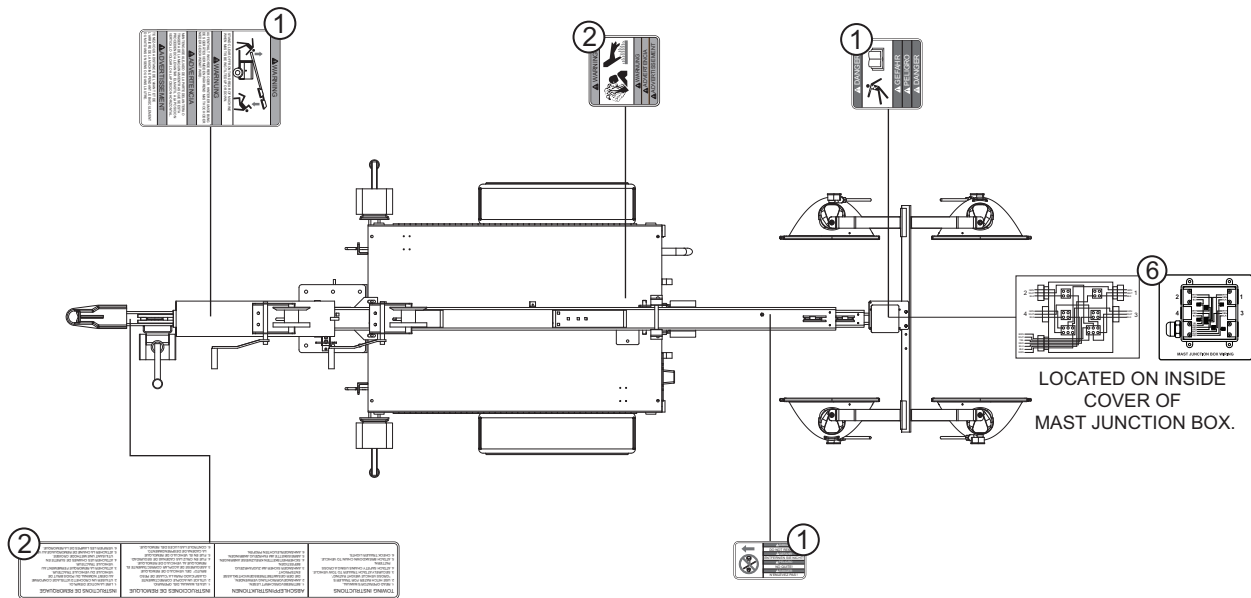

LOCATED ON INSIDE
COVER OF
MAST JUNCTION BOX.

THIS DECAL IS ALSO
LOCATED ON THE
BOTTOM SIDE OF MAST

ITEM	PART	QTY	DESCRIPTION	NOTES
1	12140	1	Decal set, common mast 4-lang.	
2	12141	1	Decal set, engine/electrical safety 4-lang.	
3	11553	1	Decal, instruction - 3000 4 lang	End S#0900186
	10588	1	Decal, instruction - 3000 oval 4 lang	Start S#0900187 - for manual winch models
4	12881	1	Decal, instruction - 3000 4 lang	End S#0900186
	10589	1	Decal, instruction - 3000 oval 4 lang	Start S#0900187 - for electric winch models
5	11275	1	Decal, Magnum logo with web	
6	12404	1	Decal, mast junction box wiring - 4 light	For units with 4 and 6 pos. spring-loaded terminal blocks.
	13614	1	Decal, mast junction box wiring - 4 light	For units with 2, 3 & 5 pos. locking terminal blocks.

MANUAL WINCH MAST ASSEMBLY

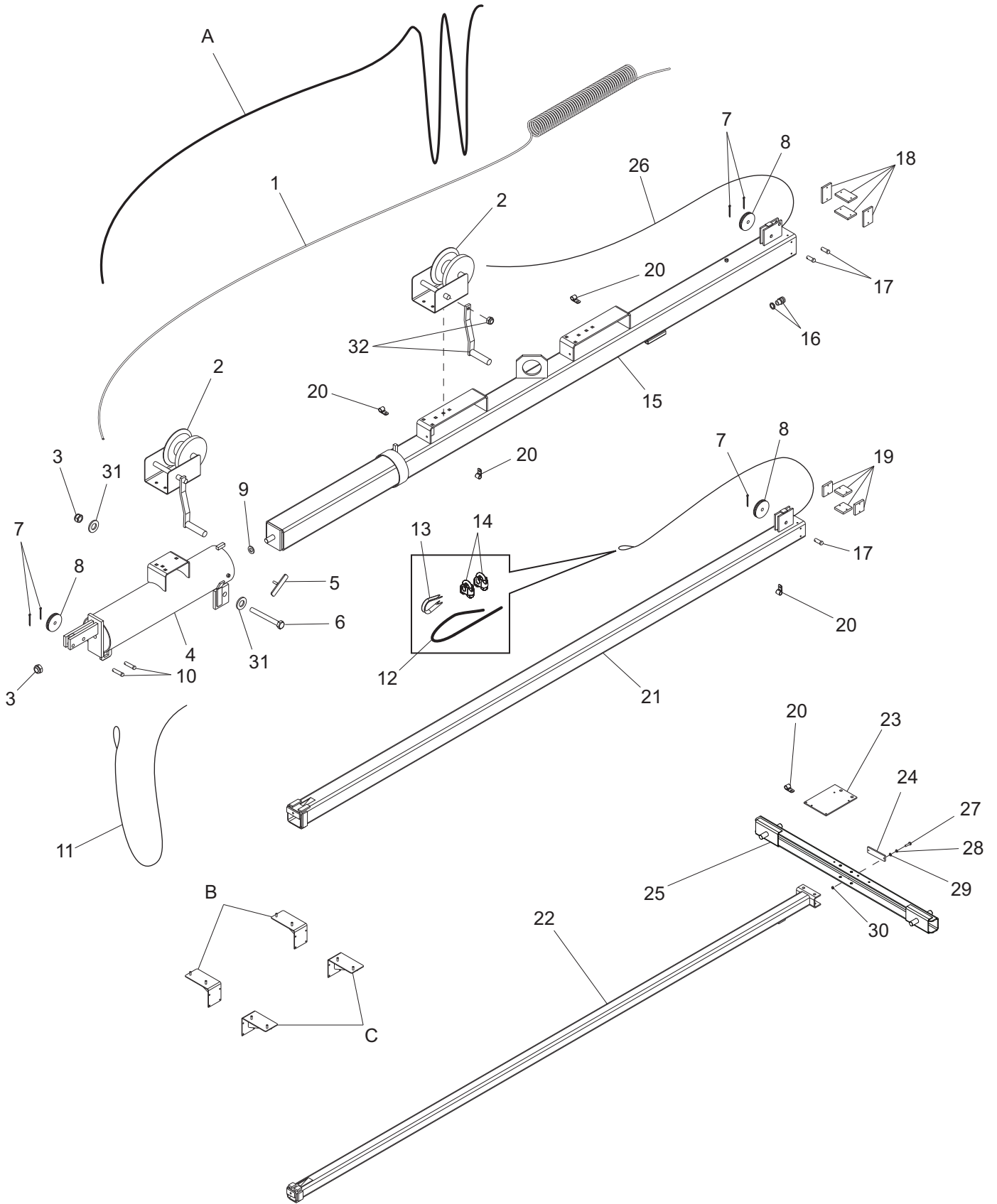

ITEM	PART	QTY	DESCRIPTION	NOTES
1	11954	1	Coil cord, mast	
2	16600	2	Winch, manual	
3	60584	2	Nut, .750-10 nylock G5 yellow zinc	
4	11902B	1	Weldment, mast tube	
5	11649Z	1	Weldment, t-bolt	
6	15292	1	Screw, .750-10x6.500 hx hd SS	
7	15380	4	Pin, cotter -.125x1.250	
8	14262	2	Sheave, 3 in.	
9	60247	1	Washer, flat .750	
10	14234	2	Pin, clevis .500 x 2.00	
11	14798	1	Cable, .188 in. x 16 ft. steel w/teardrop	
12	14151	1	Cable, .188 in. x 11 ft. steel w/swedge	
13	15003	1	Thimble, cable - .188	
14	15002	2	Clip, wire rope .188	
15	11933B	1	Weldment, mast - 4.00	
16	14439	1	Strain relief - .50 NPT, .50 cord	
17	15015	3	Pin, clevis .500 x 1.25	
18	15014	4	Shim, 2 x 3 x .281 GSM	
19	15013	4	Shim, 2 x 2 x .344 GSM	
20	16143	5	Clamp, tubing .500	
21	11934B	1	Weldment, mast - 3.00	
22	16257B	1	Weldment, mast - 2.00	
23	12095B	1	Bracket, junction box	
24	15829	1	Reflector, red	
25	13527B	1	Weldment, mast crossbar (3/4" studs)	
26	15006	1	Cable - .188 in. x 27 ft. steel w/swedge	
27	60397	1	Screw, 10-32X1.000 pan hd phil	
28	60252	2	Washer, split lock #10	
29	60237	2	Washer, flat #10	
30	14231	2	Nut, 10-32 hx	
31	60744	2	Washer, flat .750ID/1.25OD/.06th delrin	
32	15623	2	Winch handle, 9.00 in long	
A	15612	1	Cable, 16-7 cold mast drape	Option
B	13869B	2	Weldment, light storage - RH	Option
C	13870B	2	Weldment, light storage - LH	Option

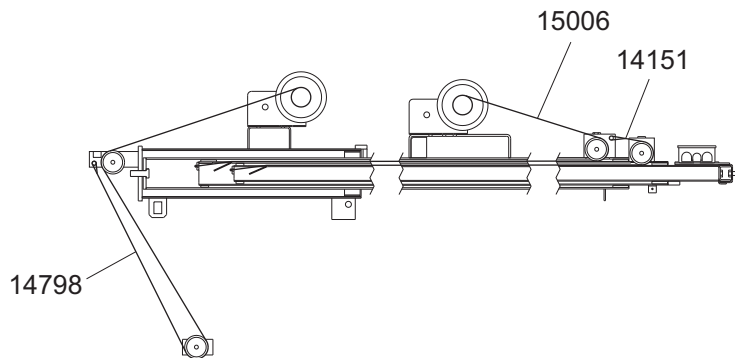

ELECTRIC WINCH MAST ASSEMBLY

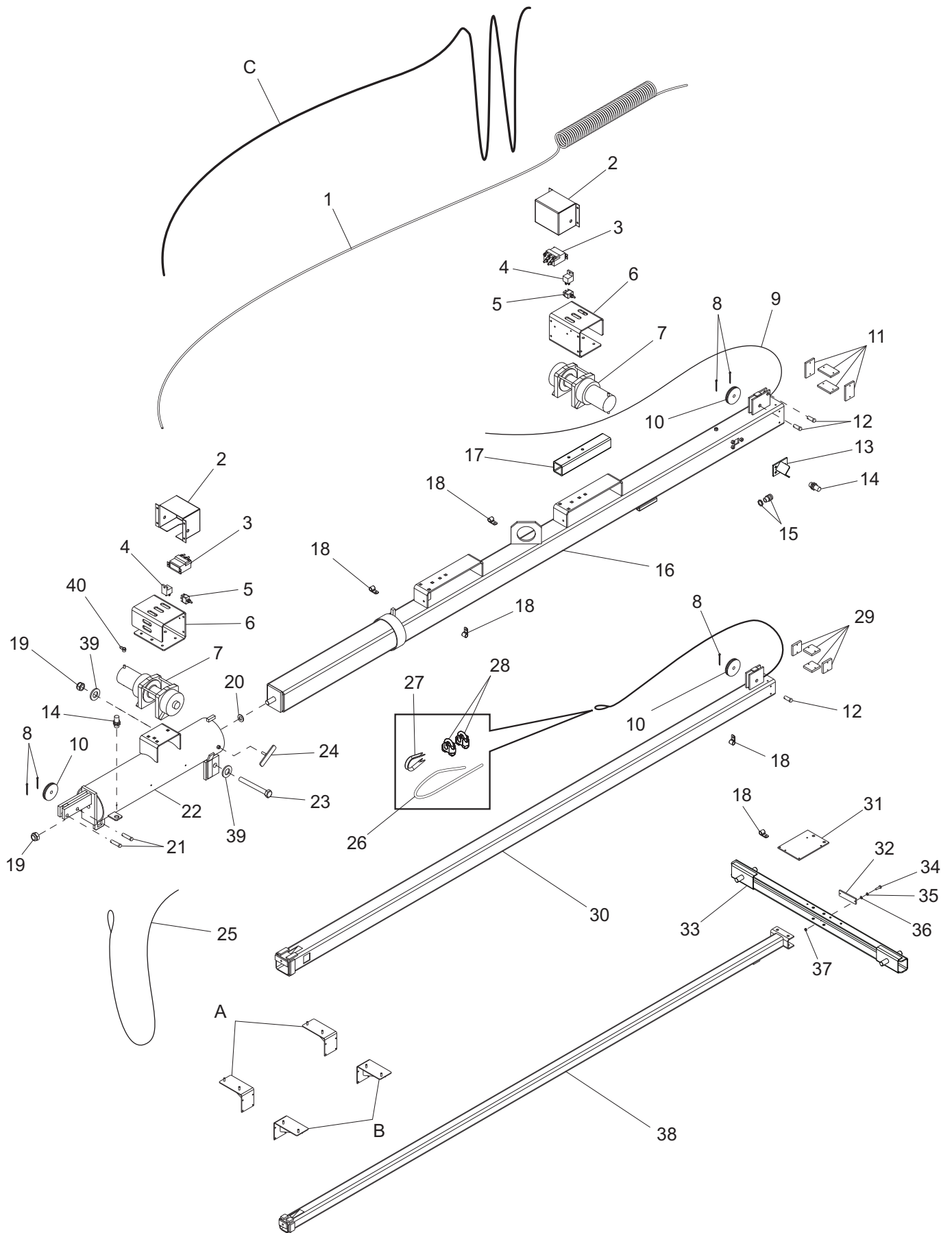

ITEM	PART	QTY	DESCRIPTION	NOTES
1	11954	1	Coil cord	
2	12875B	2	Cover, winch contactor	
3	11293	2	Contactora, electric winch - warn	
4	65049	2	Relay, 12V 30/40A N.O. w/diode	
5	65707	2	Switch, toggle - spring weatherproof	
6	12872B	2	Bracket, winch mounting	
7	12874	2	Winch, electric - 770 lb. hoist	
8	15380	5	Pin, cotter - .125x1.250	
9	15006	1	Cable, .188 in. x 27 ft. w/ball swedge	
10	14262	3	Sheave, 3 in.	
11	15014	4	Shim, 2 x 3 x .281 GSM	
12	15015	3	Pin, clevis .500 x 1.25	
13	13796B	1	Weldment, prox sensor brkt	
14	65511	2	Sensor, proximity	
15	14439	1	Strain relief- .50 NPT, .50 cord	
16	12085B	1	Weldment, 4.00 mast - Electric Winch	
17	11967B	1	Channel, electric winch mount	
18	16143	3	Clamp, tubing .500	
19	60584	2	Nut, .750-10 nylock G5 yellow zinc	
20	60247	1	Washer, flat .750	
21	14234	2	Pin, clevis .500 x 2.00	
22	12876B	1	Weldment, mast tube - Electric Winch	
23	15292	1	Screw, 750-10 x 6.50 hx hd SS	
24	11649Z	1	Weldment, t-bolt	
25	14798	1	Cable - .188 in. x 16 ft. steel w/teardrop	
26	14151	1	Cable - .188 in. x 11 ft. steel w/swedge	
27	15003	1	Thimble, cable - .188	
28	15002	2	Clip, wire rope - .188 single saddle	
29	15013	4	Shim, 2 x 2 x .344 GSM	
30	12084B	1	Weldment, 3.00 mast	
31	12095	1	Bracket, junction box	
32	15829	1	Reflector, red	
33	13527B	1	Weldment, mast crossbar (3/4" studs)	
34	60397	2	Screw, 10-32X1.000 pan hd phil	
35	60252	2	Washer, split lock #10	
36	60237	2	Washer, flat #10	
37	14231	2	Nut, 10-32 hx	
38	16257B	1	Weldment, mast - 2"	
39	60744	2	Washer, flat .750ID/1.25OD/.06th delrin	
40	12922	4	Boot, battery cable - red	
A	13869B	2	Weldment, light storage (RH)	Option
B	13870B	2	Weldment, light storage (LH)	Option
C	15612	1	Cable, 16-7 cold mast drape	Option

FRAME AND COMPONENTS

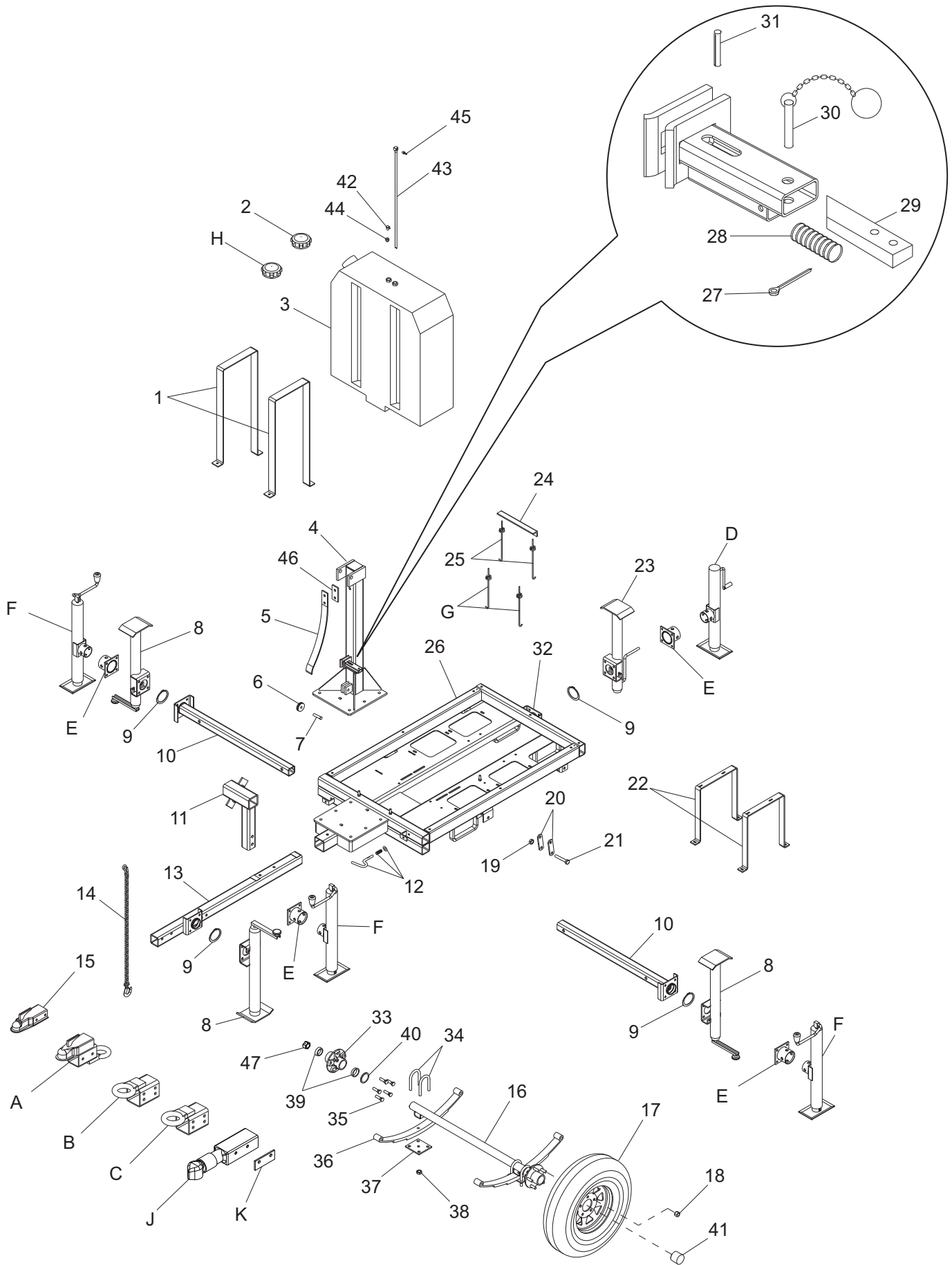

ITEM	PART	QTY	DESCRIPTION	NOTES
1	11065B	2	Bracket, fuel tank support	
2	12080	1	Cap, fuel tank vented - 3.5"	
3	11054	1	Tank, fuel 30 gal.	
4	11057B	1	Weldment, mast post	
5	14845B	1	Spring, kickback - 50 lb.	
6	14261	1	Sheave - 2 in.	
7	15015	1	Pin, clevis - .500 dia. X 1.250	
8	11682	3	Jack, top wind - 2000 lb.	
9	14326	4	Ring, retaining	
10	12431Z	2	Weldment, outrigger	
11	12235B	1	Weldment, spare tire holder	
12	14324	2	Kit, plunger	
13	12420B	1	Weldment, removable tongue	
14	23367	2	Chain, safety - 7,800 lbs. rated	
15	16830	1	Coupler, 2.00 ball/2.50 channel	
16	11100	1	Axle, 2200 lb.	
17	15976	2	Wheel, 13"	
18	60096	10	Nut, .500-20 wheel lug	
19	60504	6	Nut, .562-18 hx shackle lock	
20	19637	4	Plate, shackle bracket	
21	60503	6	Screw, .562-18 hx shackle	
22	11094B	2	Bracket, control box	
23	11681	1	Jack, side wind - 2000 lb.	
24	12924B	1	Angle, battery hold-down	
25	60820	2	Bolt, J - .250-20 X 9.00	End S#0900508
	14146	2	Bolt, J - .250-20 x 10.00	Start S#0900509
26	12017B	1	Weldment, LT chassis	
27	15380	1	Pin, cotter - .125X1.250	
28	14275	1	Spring, compression 2.75	
29	14663Z	1	Bar, latch	
30	14403	1	Pin, cotterless - .312 X 1.000	
31	15165	1	Pin, roll - .250X1.250 plain	
32	11221	1	Bracket, jack mounting - 1.25 deep	
33	11206	2	Axis Axle hub w/studs and outer races	
34	11201	4	Axis Axle U-bolt 2200 lb.	
35	11207	10	Axis Axle wheel stud .500-20	
36	16679	2	Spring - 25 in. 2200 lb.	
37	11202	2	Axis Axle tie-plate 2200 lb.	
38	11203	8	Axis Axle nut (U bolt) 2200 lb.	
39	11511	4	Axis Axle roller bearing	
40	13000	2	Axis axle seal - 2200 lb.	
41	12460	2	Axis axle, wheel bearing cap	
42	16271	1	Fitting, .250NPT X .188 hose barb	
43	11083	1	Fuel pick-up tube - 30.75 in.	
44	16270	1	Fitting, .375MNPT to .250 FNPT straight	
45	15142	1	Fitting, strt, .250NPT X .312 hose barb	
46	11554Z	1	Spacer plate - kick-back spring	
47	12308	2	Spindle nut	
A	16741B	1	Weldment, combo hitch - 2.50 tongue	Option
B	16835B	1	Weldment, lunette ring - 3.00 ID	Option
C	16999B	1	Weldment, lunette ring - 2.50 ID	Option
D	13050	1	Jack assembly, 3000# side wind	Option
E	11965Z	4	Weldment, jack adapter	Option
F	13051	3	Jack assembly, 3000# top wind	Option
G	60984	2	Bolt, J- .250-20 X 7.00	Option: gel cell battery
H	12137	1	Cap, fuel tank-vented 3.5" grn w/lanyard	Option
J	13003B	1	Coupler, 2.00 ball/3/00 channel	Option: Bulldog hitch
K	12155B	1	Spacer, coupler - black	Option: Bulldog hitch

METAL ENCLOSURE COMPONENTS

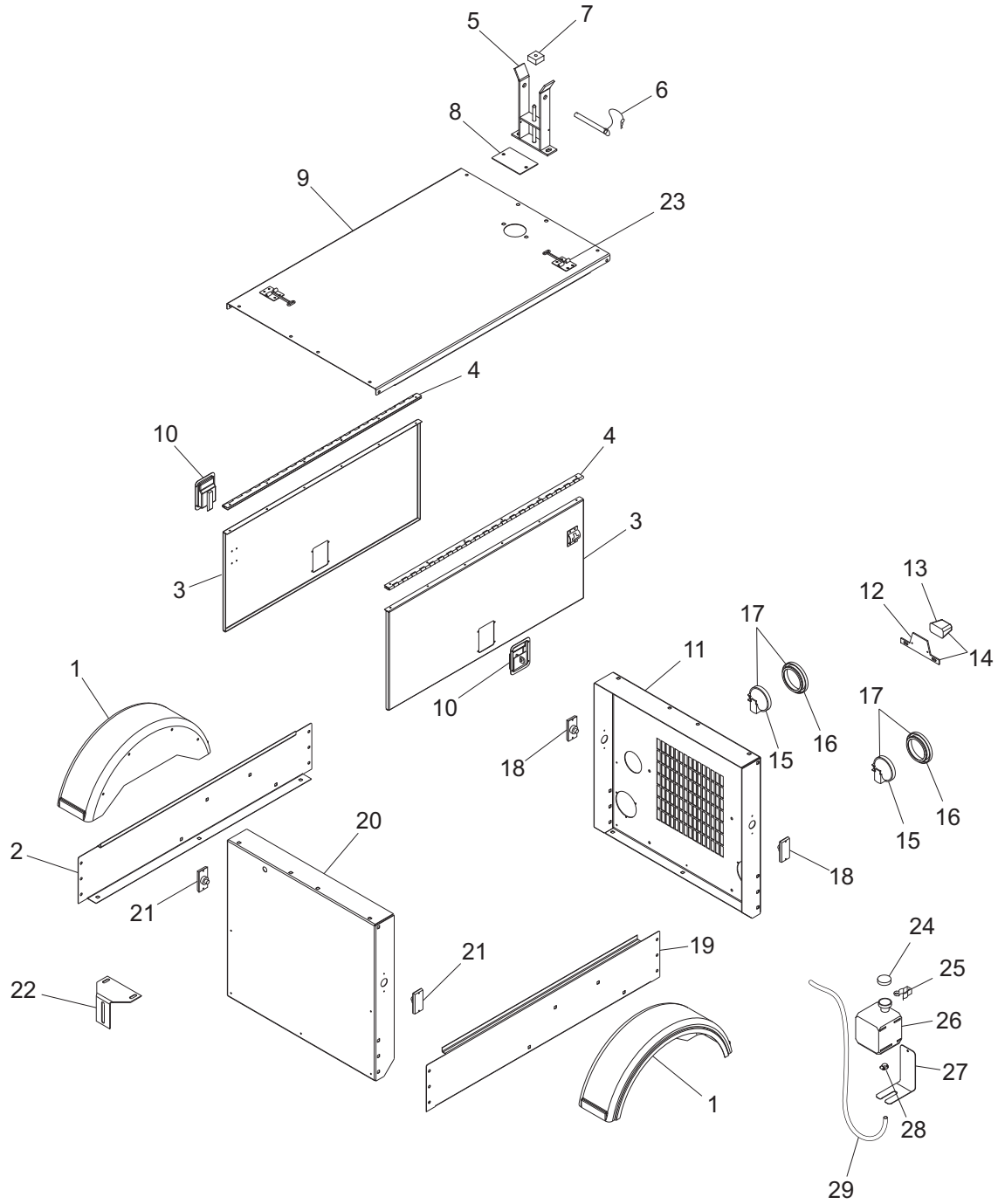

ITEM	PART	QTY	DESCRIPTION	NOTES
1	16560	2	Fender, plastic -13" tire	
2	12014W	1	Panel, side (R)	
3	11066W	2	Panel, door	
4	11095	2	Hinge, continuous - 43.00	
5	12344Z	1	Weldment, cradle - common mast	
6	16099	1	Assembly, mast cradle pin	
7	11935	1	Pad, rubber - 2.00 X 2.00 X 1.00	
8	11096W	1	Panel, radiator access	
9	11062W	1	Panel, top	
10	15123	2	Latch, paddle	
11	11060W	1	Panel, rear	
12	10224	1	Bracket, license plate	
13	10225	1	Light, license bracket	
14	10223	1	Assembly, license plate light/bracket	
15	10220	2	Light, rear tail/turn MLT no grommet	
16	10221	2	Grommet, rear light, rubber 4.5"	
17	10219	2	Assembly, rear tail/turn light	
18	65406	2	Light, clearance maker - red	
19	12015W	1	Panel, side (L)	
20	11077W	1	Panel, front	
21	65407	2	Light, clearance marker amber	
22	14459B	1	Bracket, door adjusting	
23	12605	2	Door latch SS - T style	
24	19714	1	Cap, overflow bottle	
25	19726	1	Clamp, overflow bottle	
26	20287	1	Jug, overflow 2 qt (.5 gal)	
27	22419B	1	Bracket, support overflow jug .5 gal	
28	60777	1	Clamp, hose - .312 fuel hose crimp style	
29	19220	1	Hose, overflow	
--	14410	1	Assembly, overflow jug 1.5 qt.	Items 24-29

MITSUBISHI ENGINE ASSEMBLY

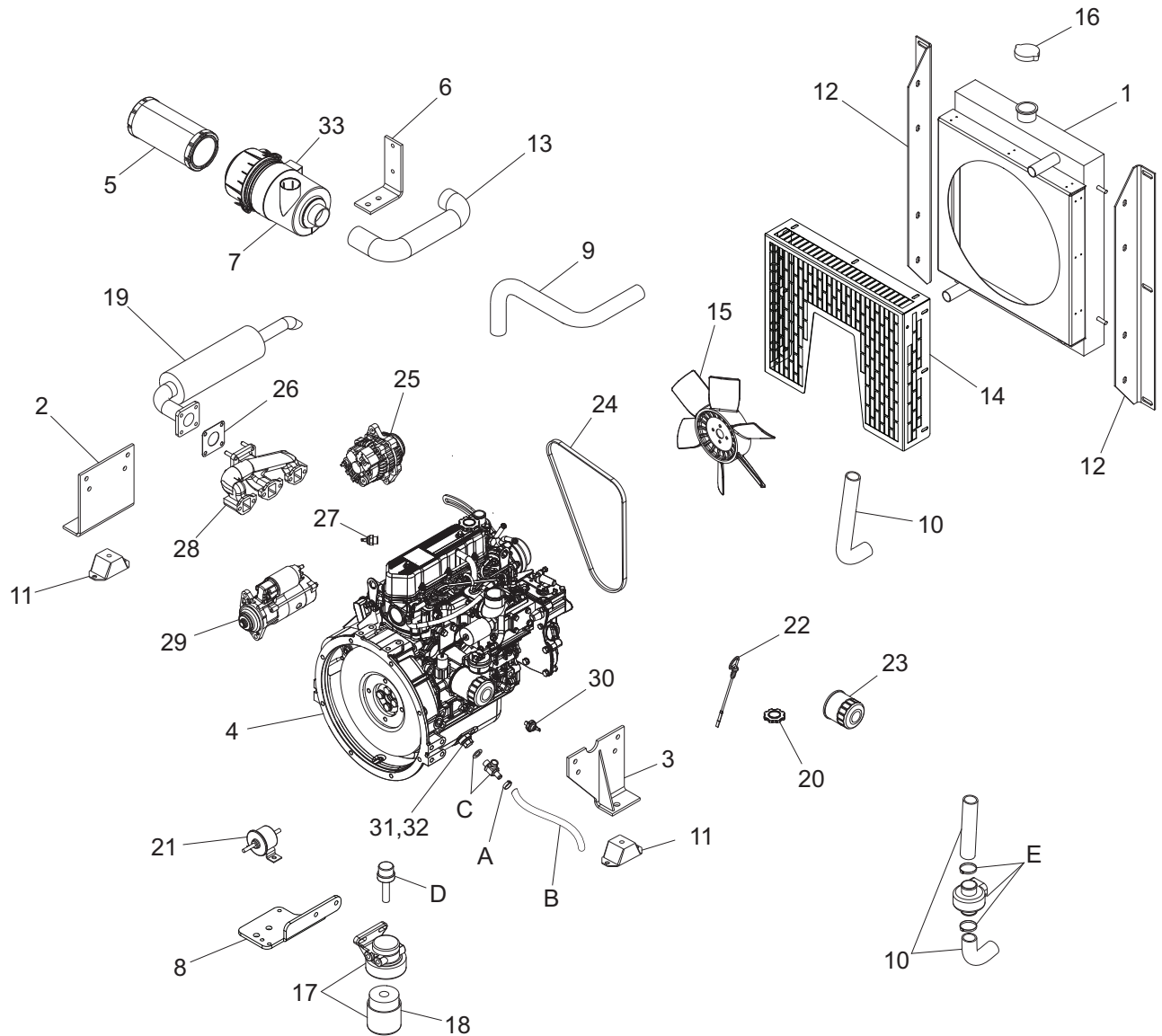

Note: Engine and generator parts used in all Magnum Products LLC equipment carry the Original Equipment Manufacturer (OEM) warranty unless otherwise stated. OEM warranty parts must be purchased through an OEM dealer. Please contact Magnum Products LLC with questions.

ITEM	PART	QTY	DESCRIPTION	NOTES
1	16540	1	Radiator w/fan guard	End S#0900191
	13924	1	Radiator w/fan guard - welded	Start S#0900192
2	16554B	1	Weldment, engine mount - LH	
3	16553B	1	Weldment, engine mount - RH	
4	16597	1	Engine, Mitsubishi L3E-W261ML	End S#081484
	13046	1	Engine, Mitsubishi - L3E int. Tier IV	Start S#081485
5	16444	1	Element, air filter	
6	16551B	1	Bracket, air cleaner	
7	16443	1	Filter, air with bracket	
8	12838B	1	Bracket, fuel filter/pump	
9	16687	1	Hose, radiator upper	
10	16688	1	Hose, radiator lower	
11	15241	4	Mount, compression	
12	11135B	2	Bracket, radiator	
13	16589	1	Hose, air cleaner	
14	11413	1	Guard, fan	
15	16742	1	Fan, engine	
16	19219	1	Cap, pressure radiator	
17	16685	1	Fuel filter head, element & fitting	
18	16686	1	Element, fuel filter	
19	15266	1	Muffler, engine	
20	11147	1	Cap, oil filler	
21	13278	1	Fuel pump, electric	
22	11148	1	Dipstick, engine oil	
23	16691	1	Filter, oil	
24	16692	1	V-belt, alternator	
25	16743	1	Alternator, Mitsubishi	
26	11042	1	Gasket, exhaust manifold	
27	16678	1	Switch, coolant temperature	
28	12529	1	Manifold, exhaust	
29	16833	1	Starter assy, engine	
30	16677	1	Switch, oil pressure	
31	12888	1	Plug, oil drain	
32	12889	1	Gasket, oil drain	
33	16445	1	Bracket, air cleaner housing	
--	16683	1	Solenoid, fuel shut-down	Not shown
--	16693	3	Glow plug, engine	Not shown
--	15074	1	Cable, battery red 38"	Not shown
--	12568	1	Cable, battery black 27"	Not shown
--	16744	1	Water pump, Mitsubishi	Not shown
--	12213	1	Mitsubishi, gasket, water pump	Not shown
--	16745	1	Thermostat, Mitsubishi	Not shown
--	12214	1	Gasket, thermostat	Not shown
--	12959	1	Mitsubishi, gasket, intake manifold L3E	Not shown
--	12214	1	Mitsubishi, gasket, thermostat	Not shown
--	16874	1	Assy, engine harness	Not shown
--	11366	1	Solenoid, starter Mitsubishi	Not shown
--	11367	1	Manifold stud	Not shown
A	60777	1	Clamp, hose - .312 fuel hose crimp style	Option
B	12227	1	Hose, oil drain .375 X 20, 30R7	Option
C	60766	1	Valve, drain 18MM-1.5 w/nipple	Option
D	13876	1	Kit, heater - fuel filter	Option
E	65649	1	Heater, engine - low rad hose	Option
--	11930	1	Cable, battery - 19" 4ga blk- 3/8"	Option: Batt. disc. - Not Shown
--	10386	1	Belt, cold weather - Mitsu 6KW & 8KW	Option: Not Shown

KUBOTA ENGINE ASSEMBLY

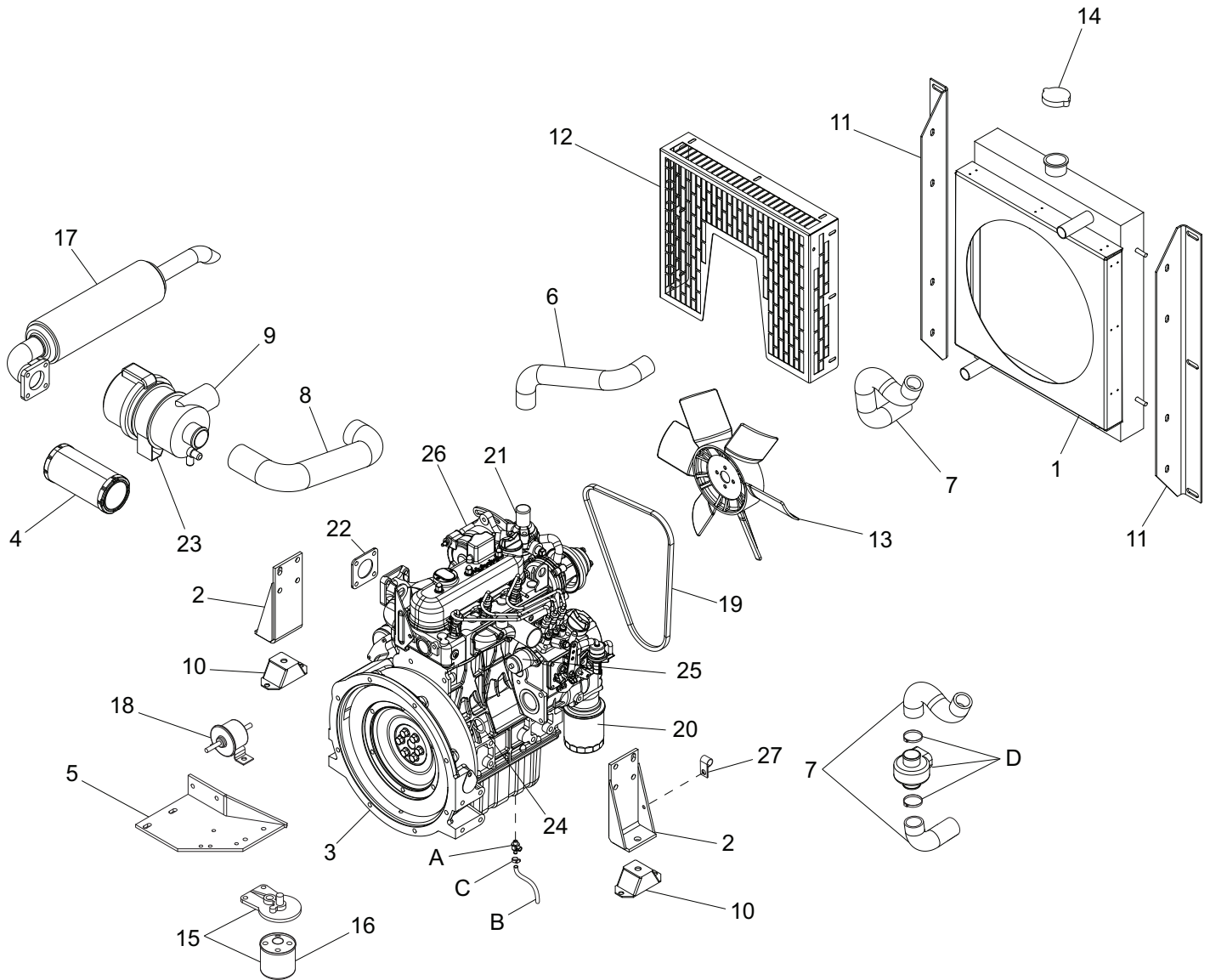

Note: Engine and generator parts used in all Magnum Products LLC equipment carry the Original Equipment Manufacturer (OEM) warranty unless otherwise stated. OEM warranty parts must be purchased through an OEM dealer. Please contact Magnum Products LLC with questions.

ITEM	PART	QTY	DESCRIPTION	NOTES
1	16540	1	Radiator w/fan guard	End S#0900191
	13924	1	Radiator w/fan guard - welded	Start S#0900192
2	12338B	2	Weldment, engine mount	
3	12286	1	Engine, Kubota D905	MLT3060
	13281	1	Engine, Kubota D1105	MLT 3080
4	16444	1	Element, air filter	
5	13483B	1	Weldment, filter bracket	
6	16687	1	Hose, radiator upper	
7	12350	1	Hose, radiator lower	
8	16589	1	Hose, air cleaner	
9	16443	1	Filter, air with bracket	
10	15241	4	Compression mount	
11	11683B	2	Bracket, radiator	
12	11413	1	Fan Guard	
13	15495	1	Kubota pusher fan	
14	19219	1	Cap, pressure radiator 14 psi	
15	13481	1	Kubota fuel filter assembly	
16	13515	1	Fuel filter element	
17	15021	1	Muffler, engine	
18	13278*	1	Kubota, fuel pump, electric	
19	11628	1	Kubota V-belt	
20	15146	1	Filter, oil	
21	12484	1	Cap, oil filler	
22	11042	1	Gasket, exhaust manifold	
23	16445	1	Bracket, air cleaner housing	
24	12483	1	Dipstick, engine oil	
25	13018	1	Solenoid, fuel shutdown (2 wire)	
26	12486	1	Alternator	
27	60649	2	Clamp, tubing - .750 heavy duty	
--	13526	1	Kubota, joint eye, double port	Not shown
--	15375	1	Switch, oil pressure	Not shown
--	14099	1	Switch, coolant temperature	Not shown
--	15074	1	Cable, battery red 38"	Not shown
--	15073	1	Cable, battery black 24"	Not shown
--	65996	1	Assy, engine harness	Not shown
A	60774	1	Valve, drain 22MM-1.5 w/nipple	Option
B	12227	1	Hose, oil drain .375 x 20, 30R7	Option
C	60777	1	Clamp, hose - .312 fuel hose crimp style	Option
D	65649	1	Heater, engine - low rad hose	Option
--	11930	1	Cable, battery - 19" 4ga blk 3/8"	Option: not shown - battery disc.

Note: The following Kubota engine parts are serial number specific. Please contact **Kubota Engine America Corp.** or the Magnum Products Technical Service Department at 1-800-926-9768 for information regarding engine parts.

--	SEE NOTE	3	Glow plug, engine	Not shown
--	SEE NOTE	1	Starter, engine	Not shown
--	SEE NOTE	1	Kubota, water pump	Not shown
--	SEE NOTE	1	Kubota, water pump gasket	Not shown
--	SEE NOTE	1	Thermostat assy	Not shown

CONTROL PANEL ASSEMBLY

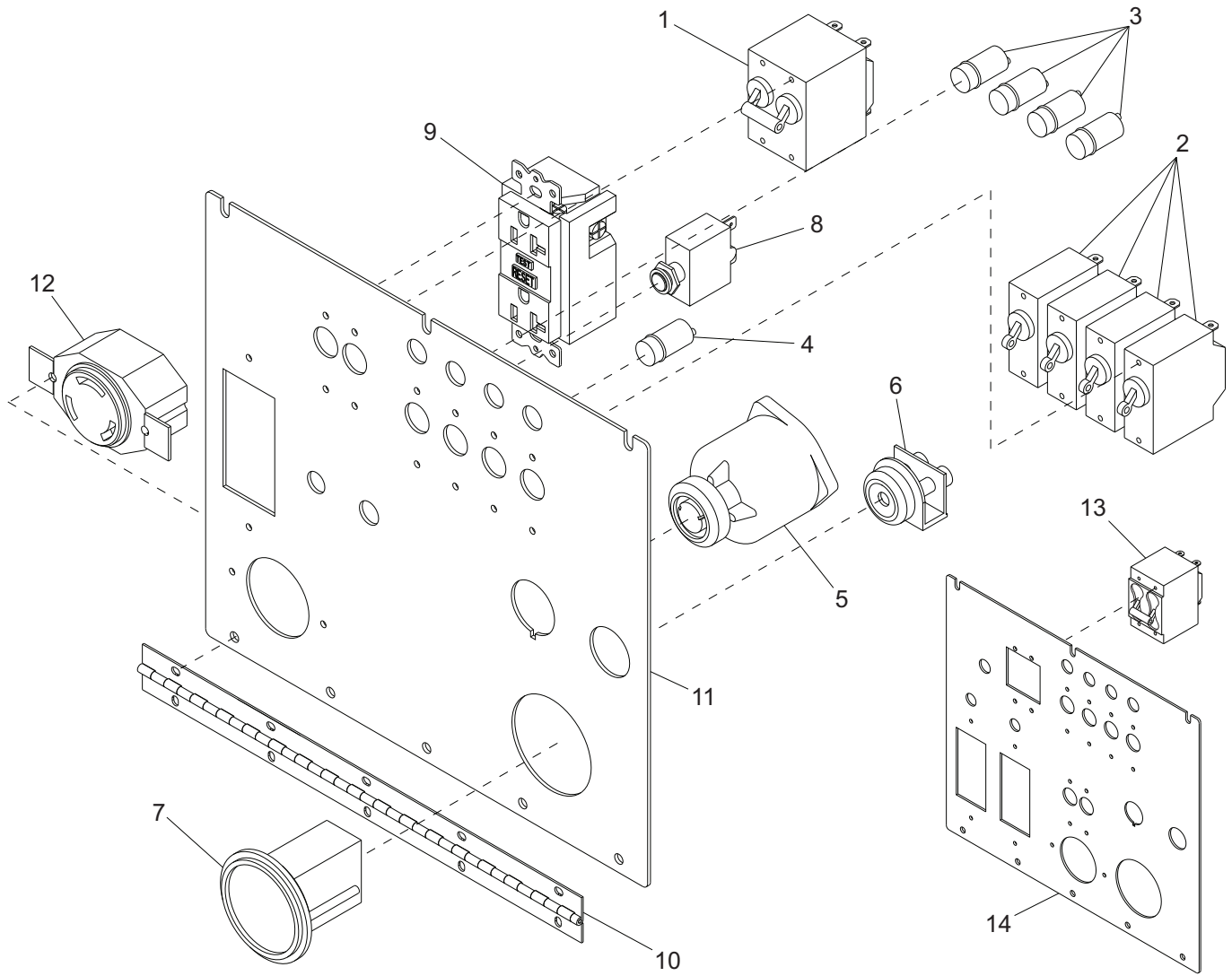

ITEM NO.	PART NO.	QTY	DESCRIPTION	NOTES
1	65851	1	Breaker, main 30A, screw term	
2	14249	4	Switch, toggle 15A	
3	65325	4	Light, indicator (ballast)	
4	65388	1	Light, indicator (main breaker)	
5	15195	1	Switch, engine	
6	16694	1	Indicator, glow plug	Mitsubishi only
7	15085	1	Gauge, hourmeter	
8	65849	1	Breaker, 20A, 120V, 1-pole, push button	
9	14130	1	Receptacle, 120V/20A GFI (5-20R) UL	
10	10081	1	Hinge, panel	
11	10235	1	Panel, control	MLT3060 only
12	14137	1	Receptacle, 240V/30A twist (L6-30R)	
13	65865	1	Breaker, 40A, screw term	MLT3080 only
14	16734	1	Panel, control	MLT3080 only
--	15309	1	Key, engine	Not shown

CONTROL BOX ASSEMBLY

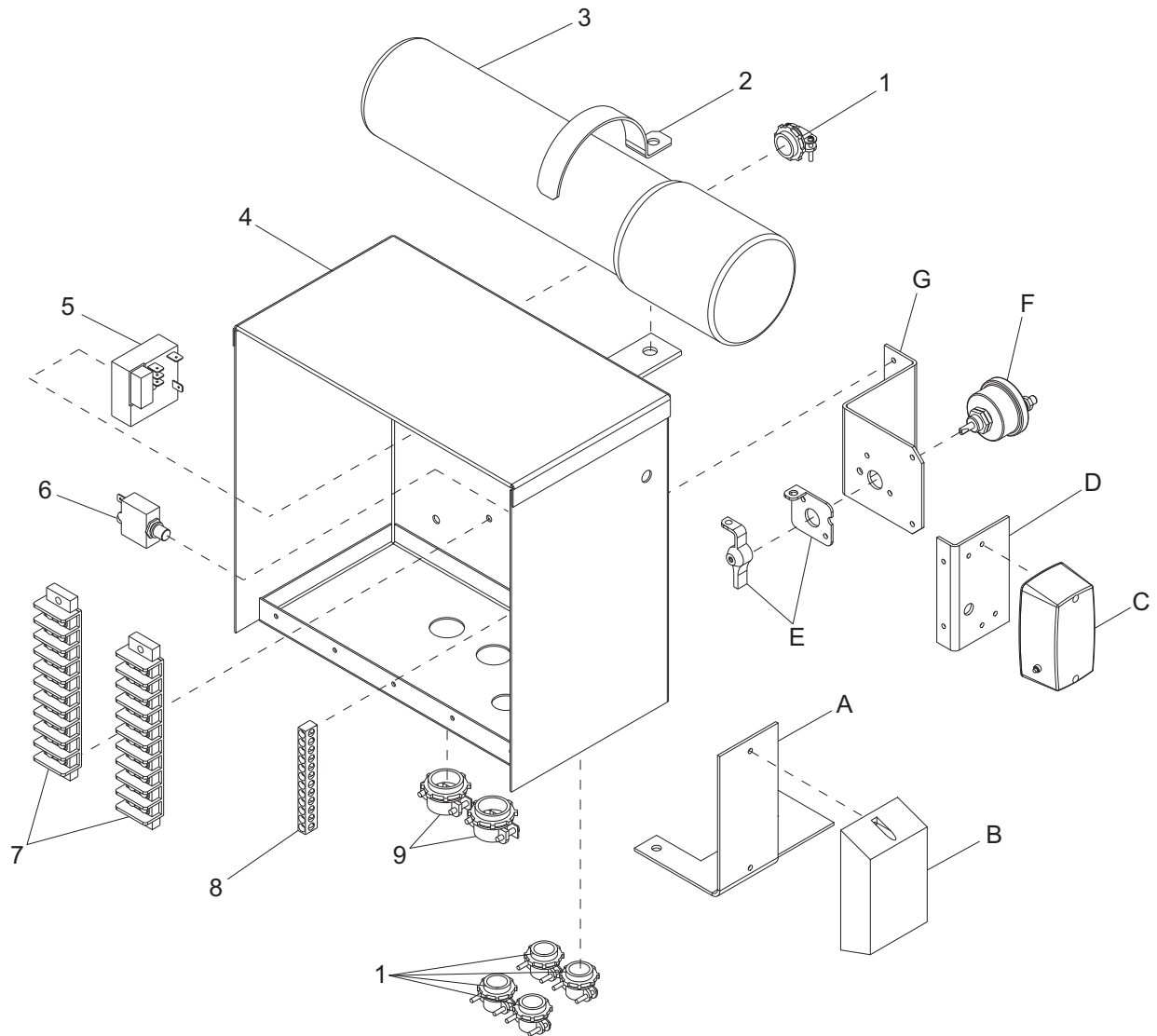

ITEM	PART	QTY	DESCRIPTION	NOTES
1	14202	5	Strain relief - .375 Romex w/nut	
2	10241	1	Clamp, 2.50 - manual holder	
3	11121	1	Tube, black manual holder, 14"	
4	14257B	1	Box, control	
5	14201	1	Relay, 15 second fixed time delay, 10A	
6	65850	1	Breaker, 10A, 240V, I-pole, push button	
7	14203	2	Block, terminal - 10 pos.	
8	14204	1	Kit, ground bar	
9	14219	2	Strain relief - .75 Romex w/nut	
A	13006B	1	Bracket, battery charger - 2A, 3 stage	Option
B	65326	1	Charger, battery - 2A, 3 stage	Option
C	11947	1	Light, interior with switch	Option
D	11949B	1	Bracket, control box light mount	Option
E	65499	1	Switch lockout lever kit	Option
F	65498	1	Switch, disconnect	Option
G	12110	1	Bracket, battery lock-out switch	Option

OVAL LIGHT ASSEMBLY

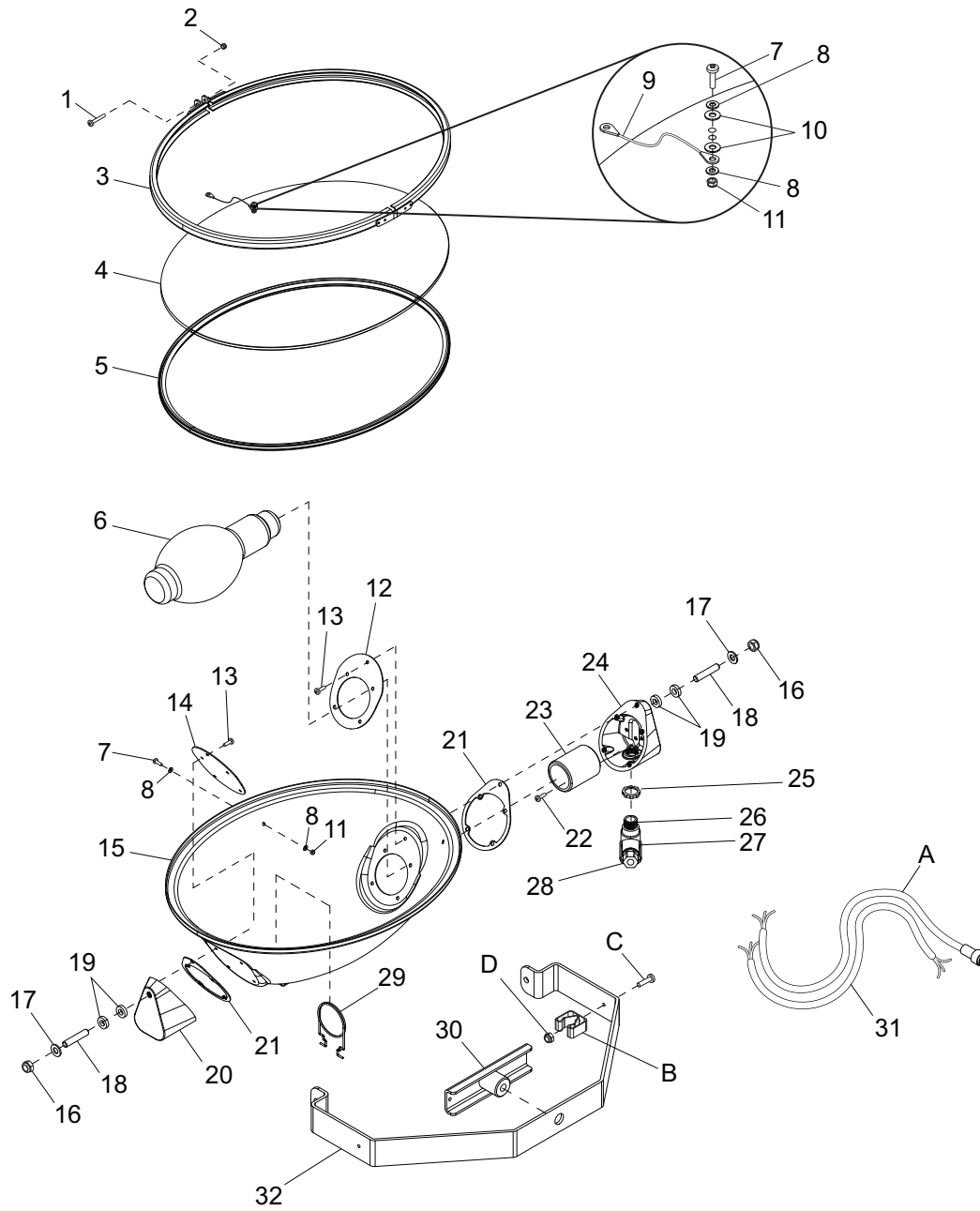

ITEM	PART	QTY	DESCRIPTION	NOTES
1	60304	1	Screw, M5 x 25 pan hd phillips	
2	60447	1	Nut, M5 nylock	
3	13367	1	Assembly, aluminum ring	
4	13369	1	Lens, glass oval	
5	13373	1	Gasket, lens oval	
6	11391	1	Bulb, 1000W MH short length	
7	13399	2	Screw, M4 x 18 pan hd phillips	
8	60067	4	Washer, #10 flat .435/.060 SS	
9	13370	1	Assembly, tether	
10	13372	2	Washer, #4 nylon	
11	60051	2	Nut, M4 nylock	
12	13376	1	Bracket, socket end plate	
13	13388	10	Screw, M5 x 12 slotted hex w/flange	
14	13377	1	Bracket, end plate	
15	13366	1	Housing	
16	60307	2	Nut, 500-13 nyk G5 ZC	
17	60309	2	Washer, .500 flat 1.060/.090 ZC SAE	
18	13392	2	Stud, trunnion	
19	13390	4	Washer, nylon (for part number 13392)	
20	13374	1	Support, housing/trunnion	
21	13378	2	Gasket, silicone	
22	13393	2	Screw, M5 x 12 phillips green	
23	13381	1	Socket, bulb	
24	13375	1	Support, housing/trunnion	
25	15861	1	Nut, special, .500 NPT lock (LN101SC)	
26	13386	1	Fitting, nipple	
27	13387	1	Connector, weather tight	
28	15864	1	Strain relief, .50 NPT watertight .270/.464 ID	
29	13892	1	Support, bulb - oval light	
30	13403	1	Handle, T - oval light (wing nut)	
31	13438	1	Cord, power hard wired	
32	13368	1	Trunnion, oval light	
--	13311	4	Assy, light fixture - 1000Whard wired	Items 1 - 32
A	13383	1	Cord, power quick disconnect	Option
B	19041	1	Clip, spring holder	Option
C	60398	1	Screw, 10-32X.500 pan phil18-8 ss	Option
D	60061	1	Nut, 10-32 nyk G5	Option
--	13601	4	Assy, light fixture/quick disconnect cord	Option

RECTANGULAR LIGHT ASSEMBLY

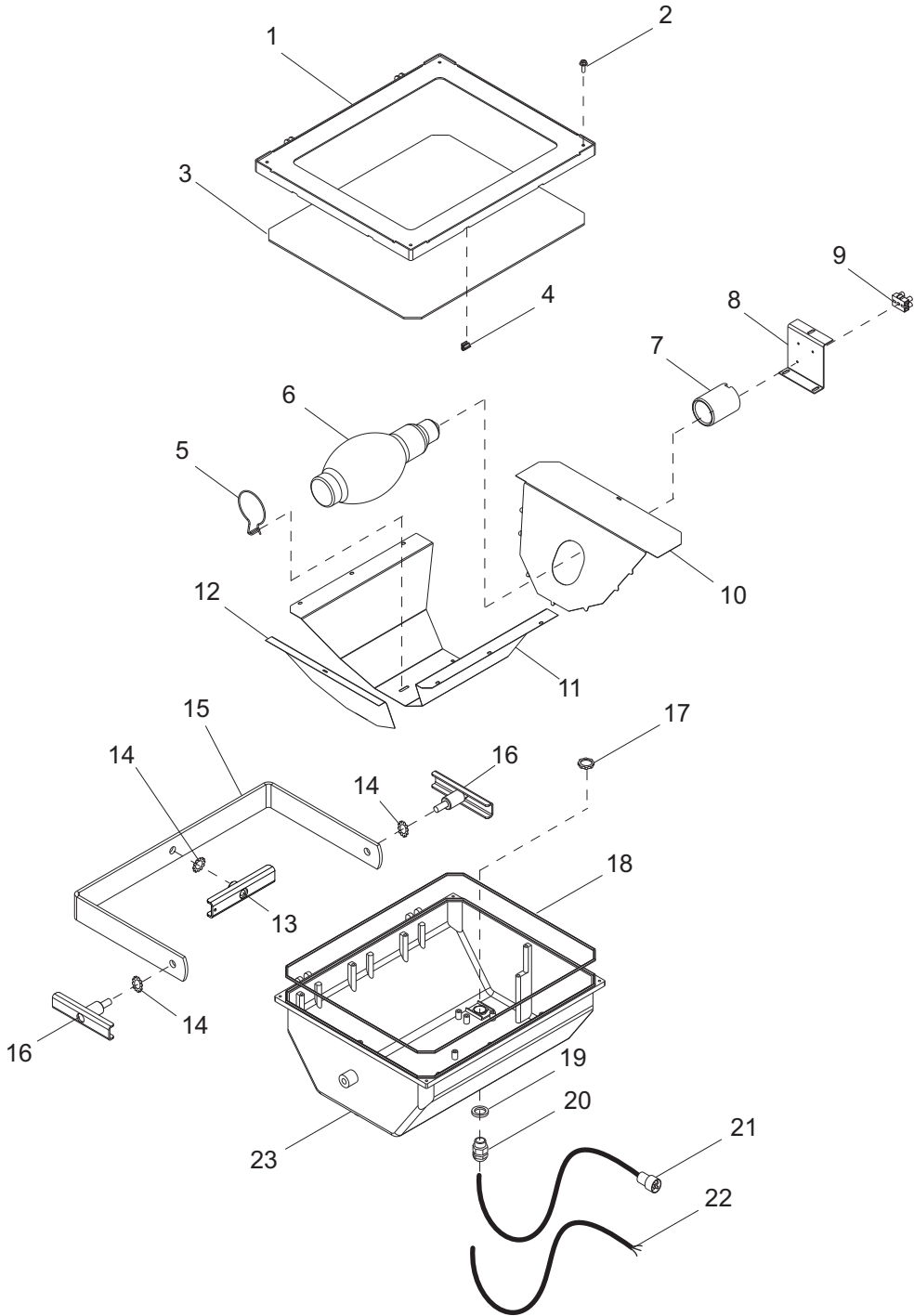

ITEM	PART	QTY	DESCRIPTION	NOTES
1	11393	1	Cover, Magnum light	
2	61059	4	Screw, 10-32X1 slot hex w/flange SS	
3	11303	1	Lens, Magnum rectangular light	
4	11392	8	Clip, glass Magnum light	
5	11398	1	Support, bulb Magnum light	
6	11391	1	Bulb - 1000W MH short length	
	11465	1	Bulb - 1000W HPS short length	
7	11394	1	Socket, Magnum light	
8	11460	1	Bracket, light socket	
9	65458	1	Block, terminal - 2 pos, 90A, 600V	
10	11424	1	Reflector, end Magnum light	
11	11399	1	Reflector, wrap around - Magnum light	
12	11423	1	Reflector, hole in end - Magnum light	
13	12993Z	1	Weldment, wing nut - Magnum light	
14	60369	3	Washer, ext star lock M12	
15	12991Z	1	Bracket, trunnion - Magnum light	
16	12992Z	2	Weldment, wing bolt - Magnum light	
17	15861	1	Nut, .500 NPT lock	
18	11456	1	Gasket, lens	
19	15697	1	Washer, rubber sealing - .500NPT	
20	15864	1	Strain relief - .50NPT watertight	
21	14166	1	Cord, 3 ft. w/quick disconnect plug	
22	11457	1	Cable, light - hard wire	
23	11400	1	Housing - Magnum light	
--	65485	1	Kit, reflector 1000W	Items 10-12
--	11402	1	Assy, light fixture - 1000W MH non quick-disc.	
--	11790	1	Assy, light fixture - 1000W HPS non quick-disc.	
--	12997	1	Assy, light fixture - 1000W MH quick disc.	
--	11955	1	Assy, light fixture - 1000W HPS quick disc.	

ROUND LIGHT ASSEMBLY

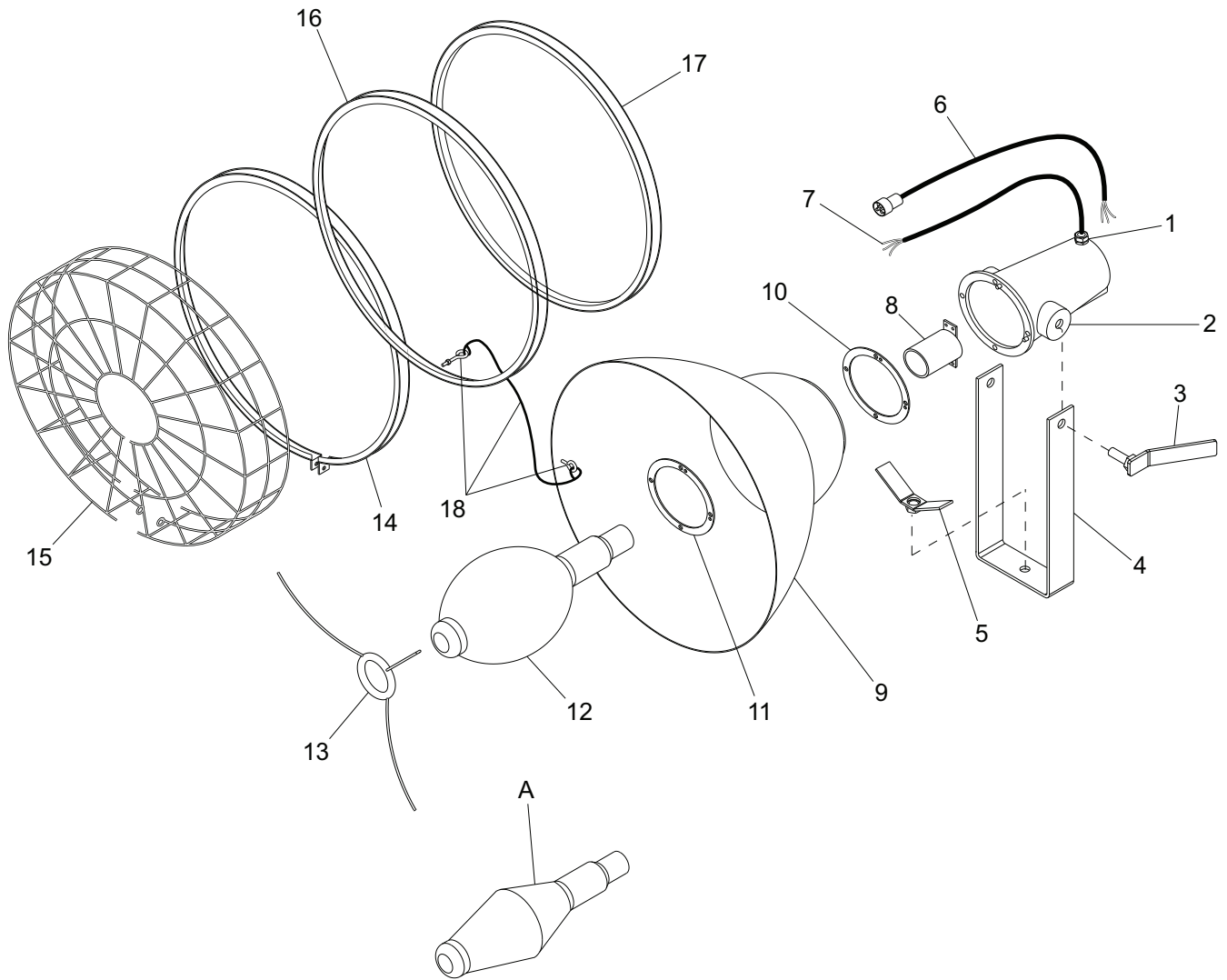

⚠ WARNING

Do not mix metal halide and high pressure sodium bulbs or parts. Equipment damage or personal injury may result.

ITEM	PART	QTY	DESCRIPTION	NOTES
1	15864	1	Connector, cord	
2	15971	1	Housing, aluminum	
3	15392Z	2	Weldment, lamp level arm	
4	14632	1	Yoke, light	
5	12794Z	1	Weldment, wing nut - extended light	
6	14166	1	Cord, quick disconnect (optional)	
7	14634	1	Cord, hard wired light	
8	14730	1	Socket, light	
9	16758	1	Reflector, aluminum	
10	16499	1	Gasket, hood	
11	16272	1	Ring, reinforcement	
12	14217	1	Bulb, metal halide	
13	16761	1	Support, bulb	
14	16718	1	Ring, clamp	
15	16763	1	Guard, lens (optional)	
16	16750	1	Lens, light	
17	16769	1	Lens, gasket	
18	16757	1	Assembly, cable	
--	16746	-	Fixture, complete	Quick disconnect
--	16747	-	Fixture, complete	Hardwired cord
A	14784	1	Bulb, high pressure sodium	Option
--	16759	-	Fixture, complete - quick disconnect	Option: high pressure sodium
--	16760	-	Fixture, complete - hardwired cord	Option: high pressure sodium

SPERO RECTANGULAR LIGHT ASSEMBLY

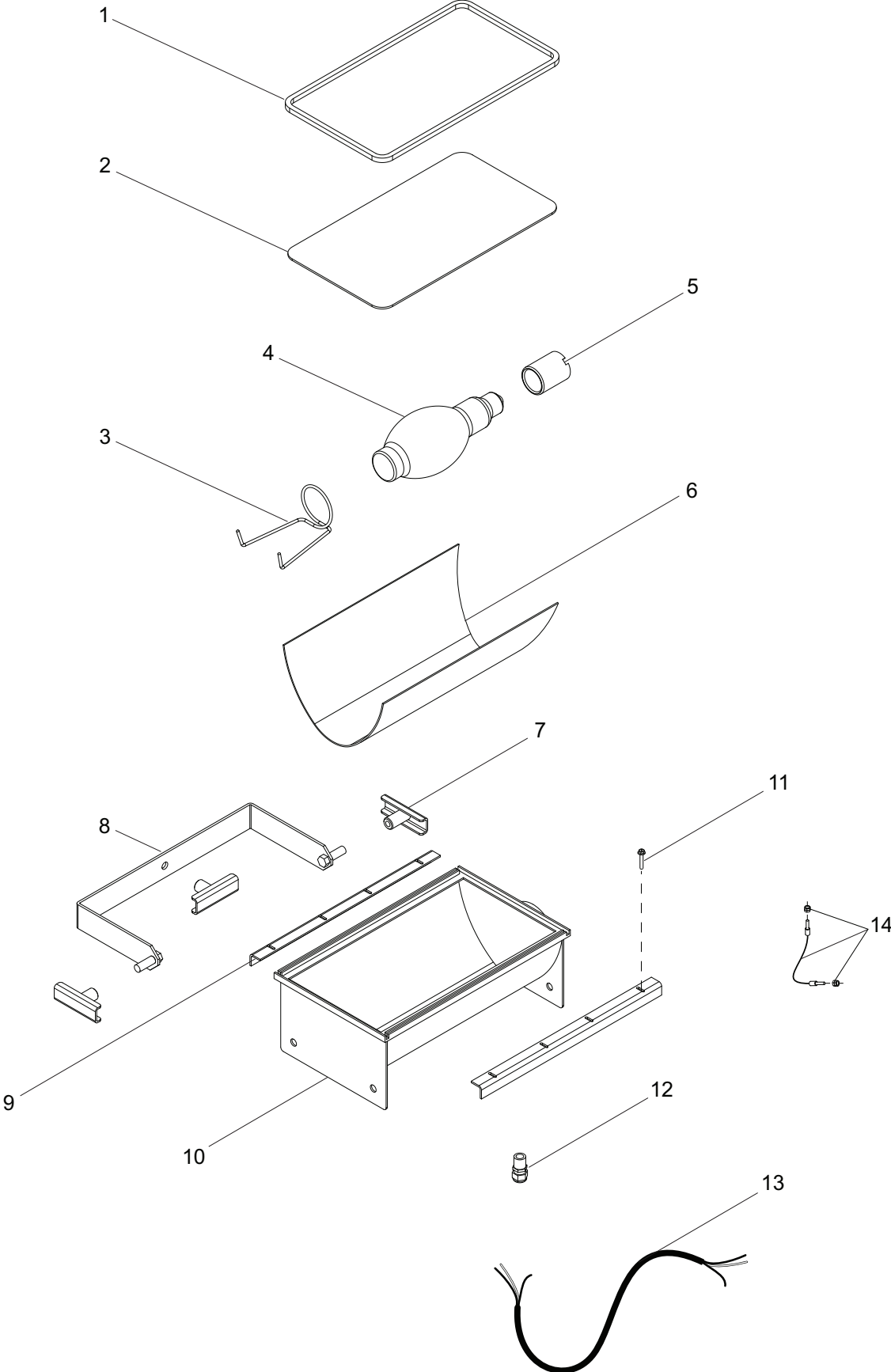

ITEM	PART	QTY	DESCRIPTION	NOTES
1	12800	1	Gasket, lens - extruded light	
2	12802	1	Lens, extruded light	
3	12801	1	Support, bulb - extruded light	
4	11391	1	Bulb - 1000W MH short length	
5	11394	1	Socket, Magnum light	
6	12809	1	Reflector, extruded light	
7	12794B	3	Weldment, wing nut - extruded light	
8	12796B	1	Weldment, bracket - trunnion	
9	12803	2	Cover, extruded light	
10	12797	1	Housing - extruded light	
11	60964	8	Screw, 10-24X1.000 slotted hx hd	
12	15864	1	Strain relief - .50 NPT watertight	
13	12799	1	Cord, extruded light - quick disconnect	
--	12804	1	Cord, extruded light - non quick disconnect	
14	12819	1	Assy, cable - lens holder - extruded	
15	12810	1	Assy, complete - quick disconnect	
16	12811	1	Assy, complete - non quick disconnect	

MAST JUNCTION BOX ASSEMBLY - QUICK DISCONNECT LIGHTS

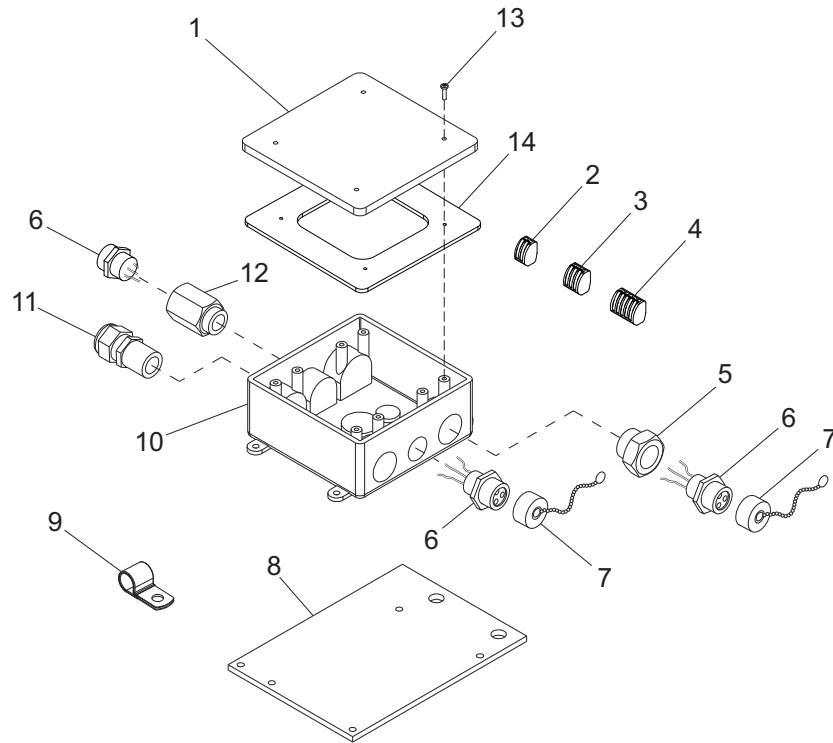

ITEM	PART	QTY	DESCRIPTION	NOTES
1	12109	1	Box cover, 2-gang plastic	
2	66100	4	Connector, 2 pos. Wago	
3	66101	2	Connector, 3 pos. Wago	
4	66102	1	Connector, 5 pos. Wago	
5	60755	2	Fitting, .750MNPT x .500FNPT nylon	
6	15403	4	Connector, quick disconnect (female)	
7	15404	4	Cap, receptacle w/chain	
8	12095B	1	Bracket, junction box	
9	16143	1	Clamp, tubing .500	
10	12094	1	Box, junction	
11	14656	1	Strain relief, .750NPT water tight	
12	12713	1	Fitting, adapter-1/2"-14 M to 1/2"-14 F	
13	60424	4	Screw, 6-32x.750 pan phil G2 ZC	
14	13749	1	Gasket, junction box - HFI 281000	
-	11957	-	Assembly, mast junction box	

MAST JUNCTION BOX ASSEMBLY - HARD WIRED LIGHTS

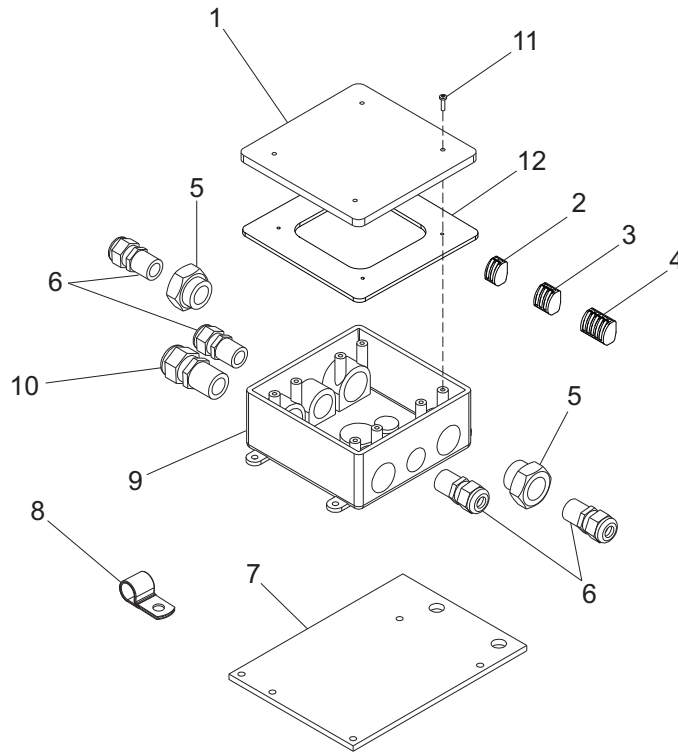

ITEM	PART	QTY	DESCRIPTION	NOTES
1	12109	1	Box cover, 2-gang plastic	
2	66100	4	Connector, 2 pos. Wago	
3	66101	2	Connector, 3 pos. Wago	
4	66102	1	Connector, 5 pos. Wago	
5	60755	2	Fitting, .750MNPT x .500FNPT nylon	
6	15864	4	Strain relief, .500NPT water tight	
7	12095B	1	Bracket, junction box	
8	16143	1	Clamp, tubing .500	
9	12094	1	Box, junction	
10	14656	1	Strain relief, .750NPT water tight	
11	60424	4	Screw, 6-32X.750 pan phil G2 ZC	
12	13749	1	Gasket, junction box - HFI 281000	
-	11789	-	Assembly, mast junction box	

METAL HALIDE BALLAST BOX ASSEMBLY

▲ WARNING

DO NOT mix metal halide and high pressure sodium ballast parts!

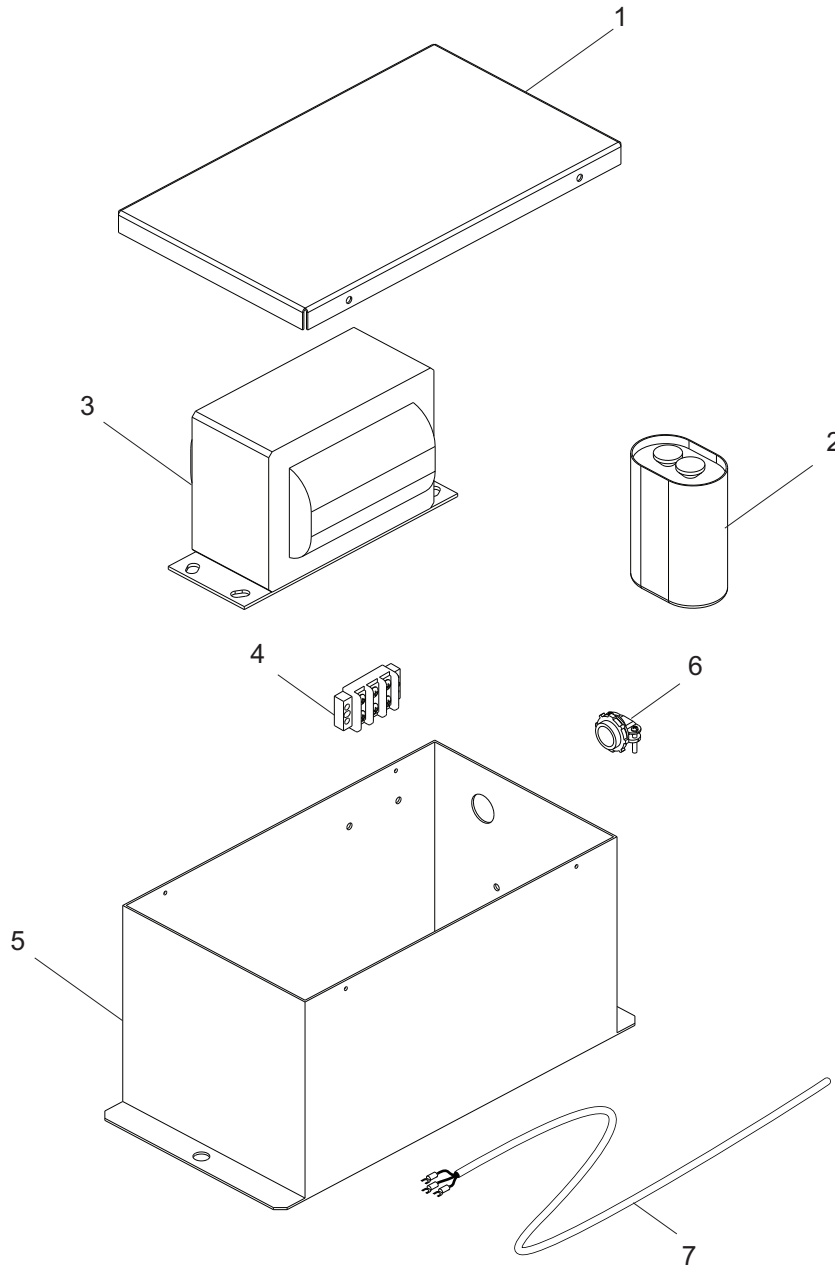

ITEM	PART	QTY	DESCRIPTION	NOTES
1	11079	1	Cover, ballast box	
2	14679	1	Capacitor, metal halide	
3	11166	1	Transformer, metal halide	
--	10227	1	Assembly, transformer & cap set	
4	14158	1	Block, terminal	
5	11078	1	Box, ballast	
6	14202	1	Strain relief, .375 Romex w/nut	
--	11144	1	Assembly, ballast box complete	Items 1-6
7	16214	1	Assembly, ballast cable	

HIGH PRESSURE SODIUM BALLAST BOX ASSEMBLY

▲ WARNING

DO NOT mix high pressure sodium and metal halide ballast parts!

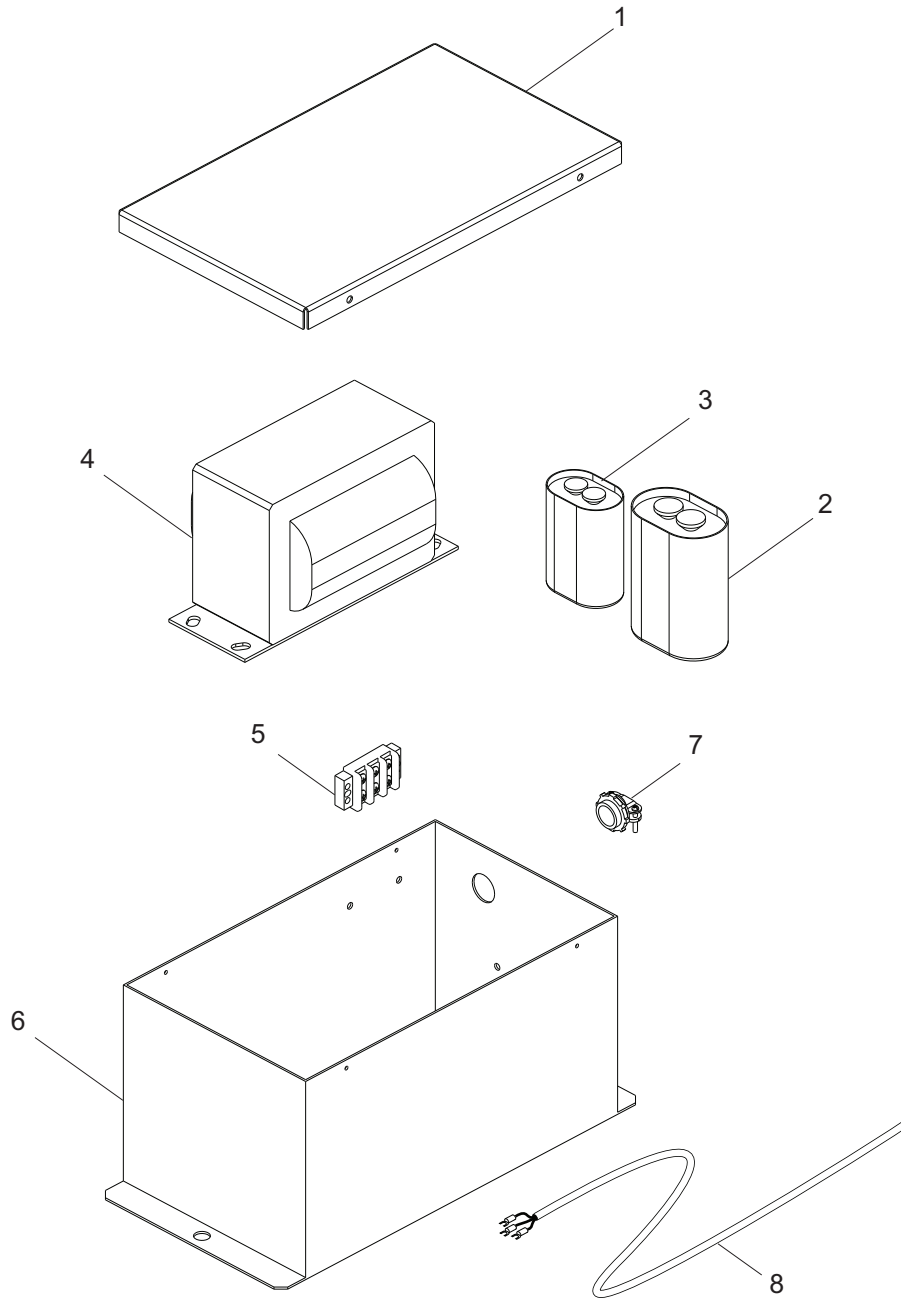

ITEM	PART	QTY	DESCRIPTION	NOTES
1	11079	1	Cover, ballast box	
2	14782	1	Capacitor, sodium light	
3	14783	1	Ignitor, sodium light	
4	11167	1	Transformer, sodium light	
--	11168	1	Assembly, transformer & cap set	
5	14158	1	Block, terminal	
6	11078	1	Box, ballast	
7	14202	1	Strain relief, .375 Romex w/nut	
--	11326	1	Assembly, ballast box complete	Items 1-7
8	16214	1	Assembly, ballast cable	

6 KW GENERATOR ASSEMBLY

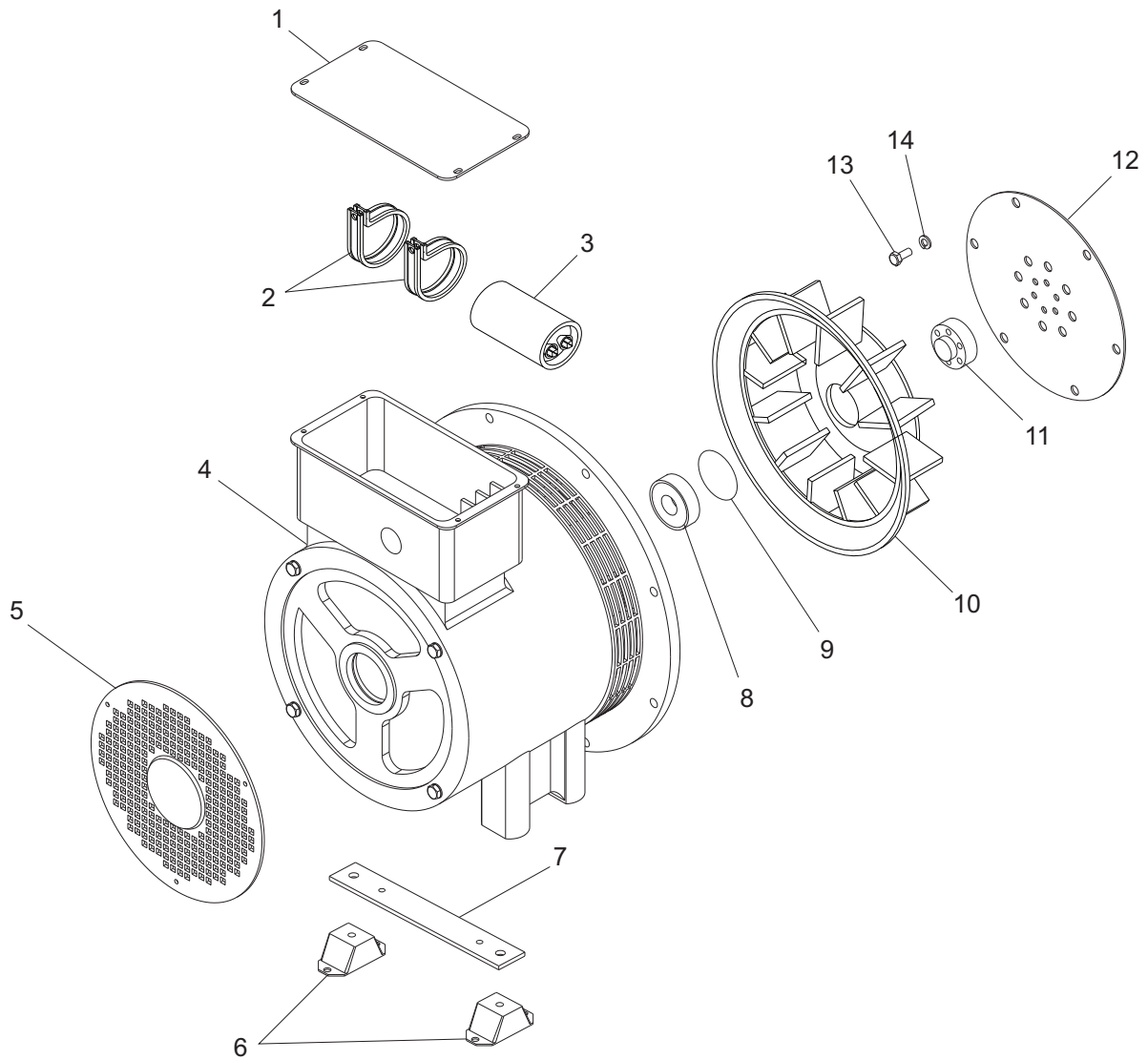

ITEM	PART	QTY	DESCRIPTION	NOTES
1	12736	1	Marathon gen box cover, 6KW-20KW	
2	16395	2	Capacitor clamp	
3	12159	1	Capacitor, 25 μ F Marathon 6KW	
	15695	1	Capacitor, 45 μ F Marathon	
4	16556	1	Generator, 6 kW 60Hz capacitor	
5	12327	1	Marathon 6KW pancake case cover	
6	15241	2	Compression mount, engine/generator	
7	15045	1	Generator mounting bar	
8	12328	1	Marathon 6KW pancake bearing	
9	12329	1	Marathon 6KW pancake bearing seal	
10	12527	1	Fan, Marathon 6KW gen (model 201)	
	16421	1	Generator fan blade 6KW (model 332)	
11	11339	1	Generator drive plate spacer	
12	16123	1	Plate, drive - SAE 6.5	
13	60410	6	Screw, M8x1.25x16 hx hd	
14	60029	6	Washer, split lock M8	

Note: Engine and generator parts used in all Magnum Products LLC equipment carry the Original Equipment Manufacturer (OEM) warranty unless otherwise stated. OEM warranty parts must be purchased through an OEM dealer. Please contact Magnum Products LLC with questions.

8 KW GENERATOR ASSEMBLY

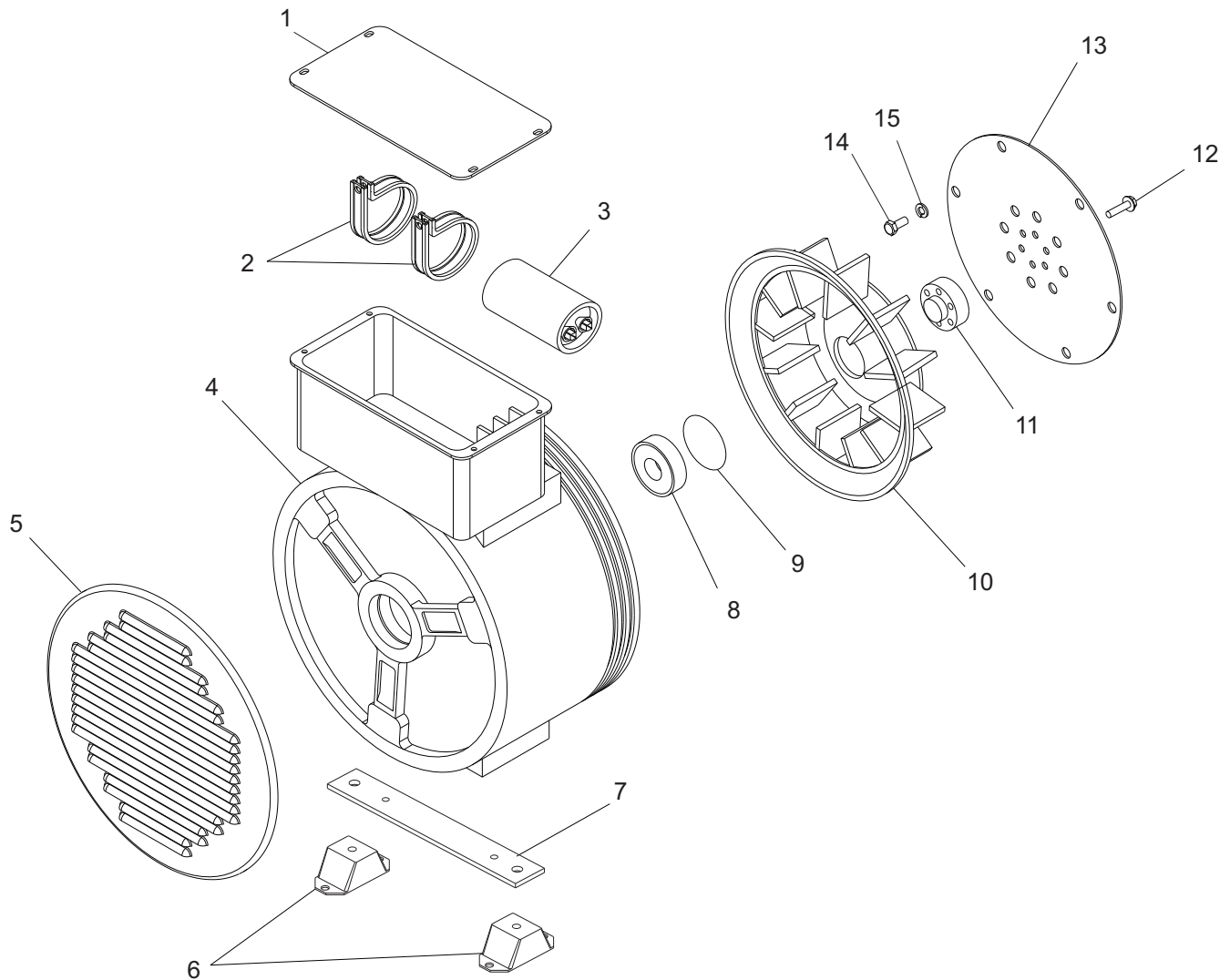

ITEM	PART	QTY	DESCRIPTION	NOTES
1	12736	1	Cover, generator box	
2	16395	2	Capacitor clamp	
3	15695	1	Capacitor, generator 45 μ F	
	15798	-	Capacitor, 50 μ F, 440VAC, 50/60 Hz	
4	15212	1	Generator, 8kw 60 Hz capacitor	End SN: 0900431
	10486	1	Generator, 8kw, cap regulated	Start SN: 0900432
5	11338	1	Generator end cover	
6	15241	2	Compression mount, engine/generator	
7	15045	1	Generator mounting bar	
8	16134	1	Bearing, 6 kW	
9	11337	1	Generator O-ring	
10	16421	1	Generator fan blade	
11	11339	1	Generator drive plate spacer	
12	11336	6	Generator screw - .375-24 x .875	
13	16123	1	Plate, drive	
14	60410	6	Screw, M8x1.25x16 hx hd	
15	60029	6	Washer, split lock M8	
--	15493	2	Diode, rotor	Not shown
--	15492	1	Suppressor	Not shown

Note: Engine and generator parts used in all Magnum Products LLC equipment carry the Original Equipment Manufacturer (OEM) warranty unless otherwise stated. OEM warranty parts must be purchased through an OEM dealer. Please contact Magnum Products LLC with questions.

AC WIRING DIAGRAM - MLT3060

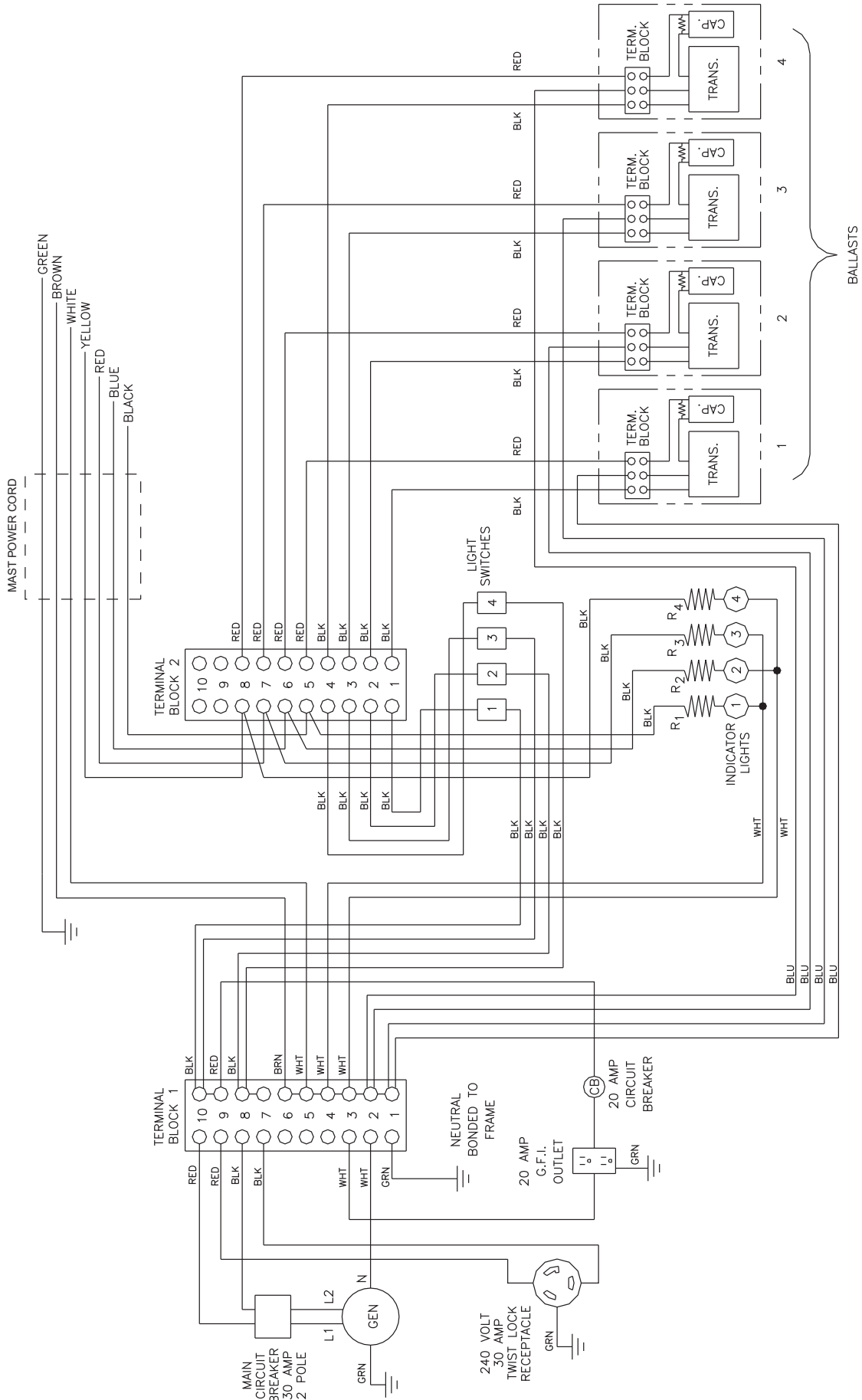

AC WIRING DIAGRAM - MLT3080

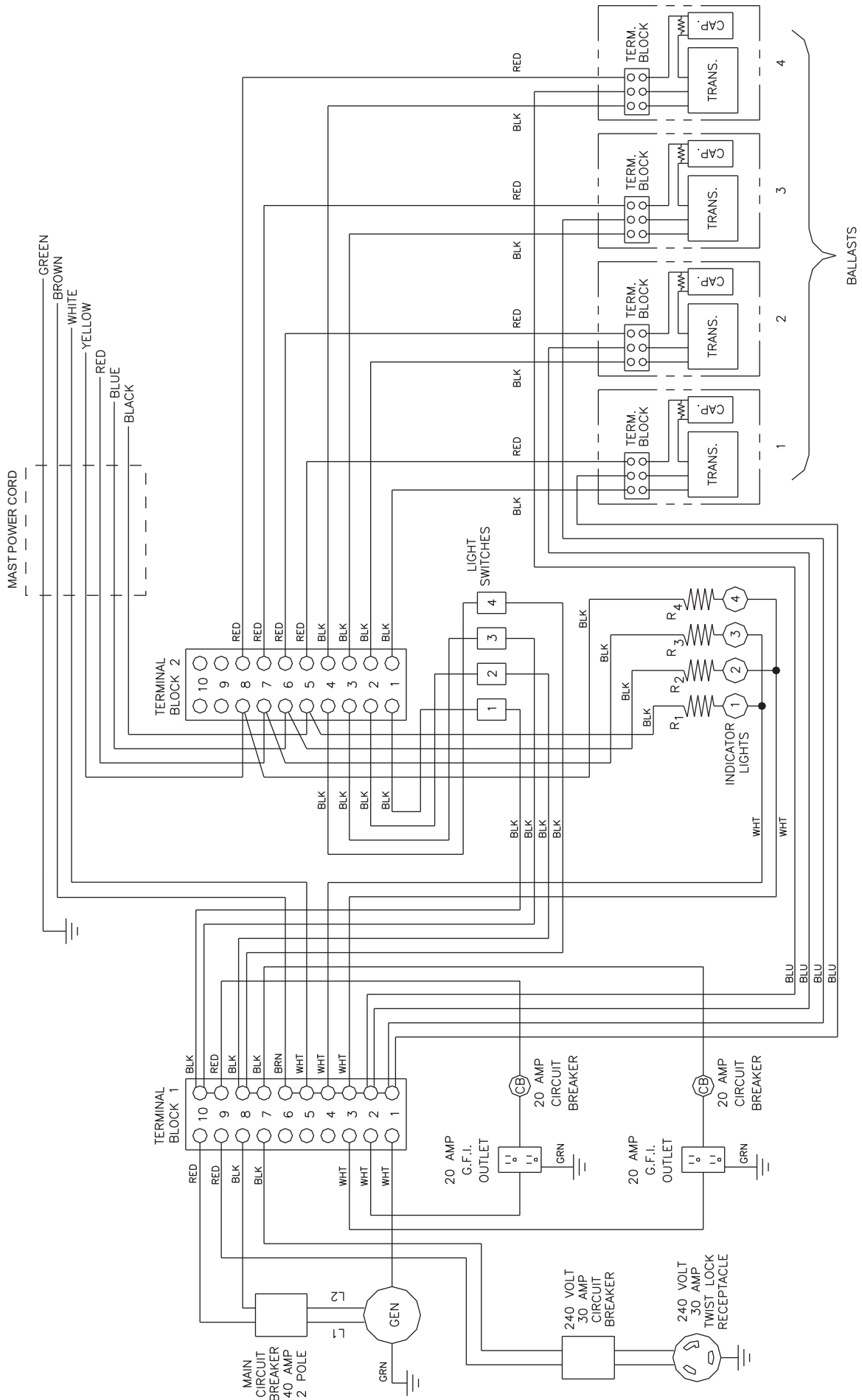

DC WIRING DIAGRAM - MITSUBISHI

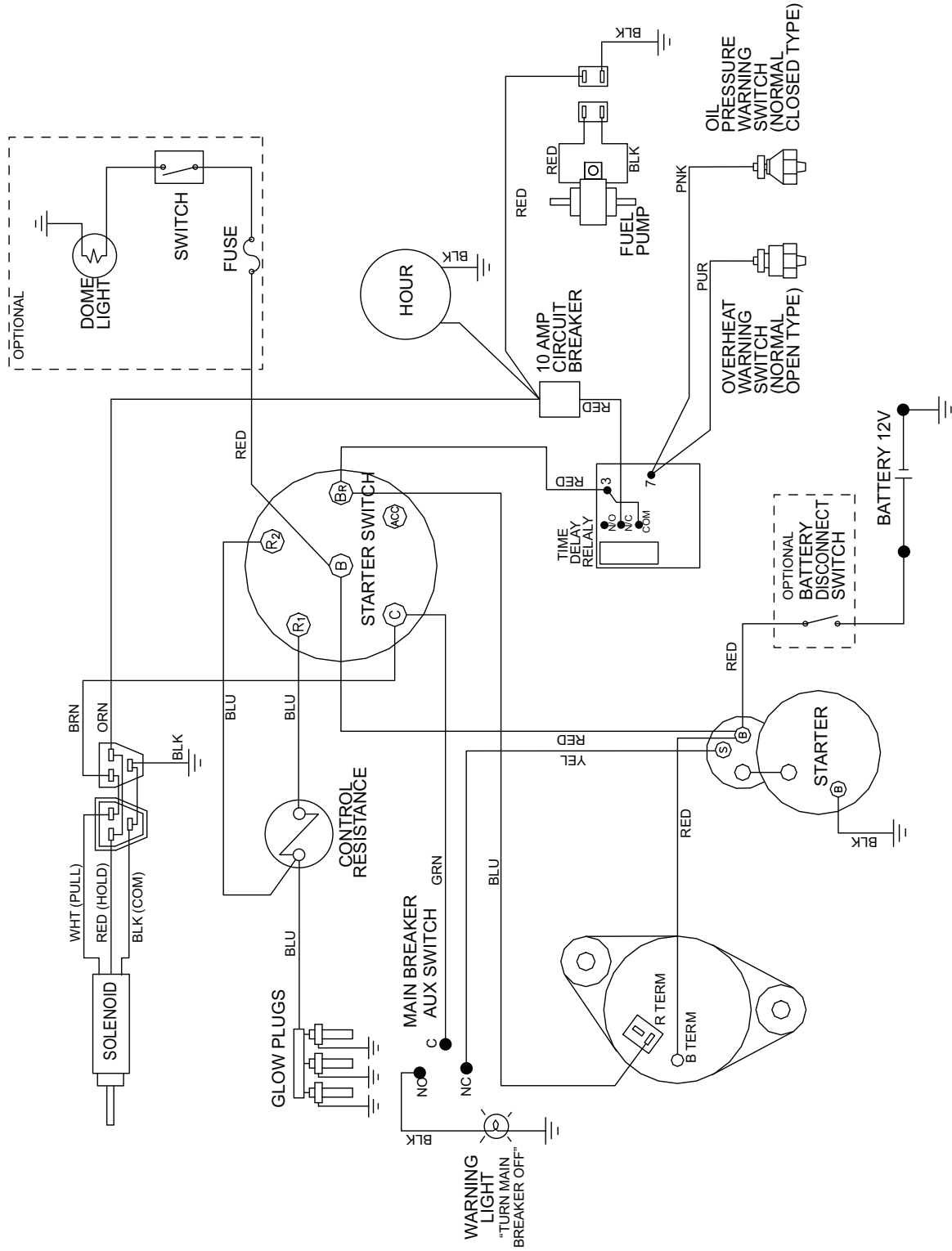

DC WIRING DIAGRAM - KUBOTA

End S#0900090

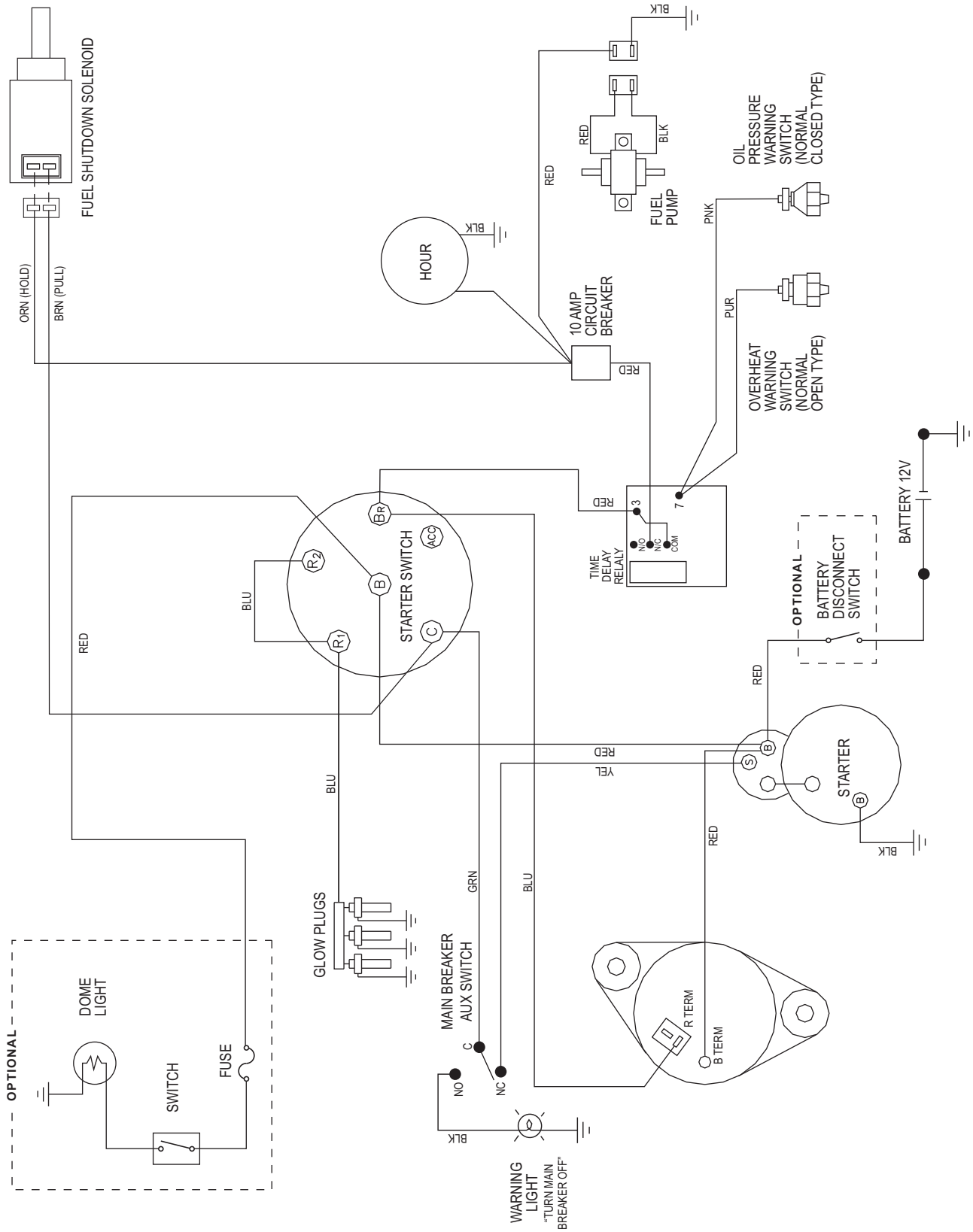

DC WIRING DIAGRAM - KUBOTA

Start S#0900091

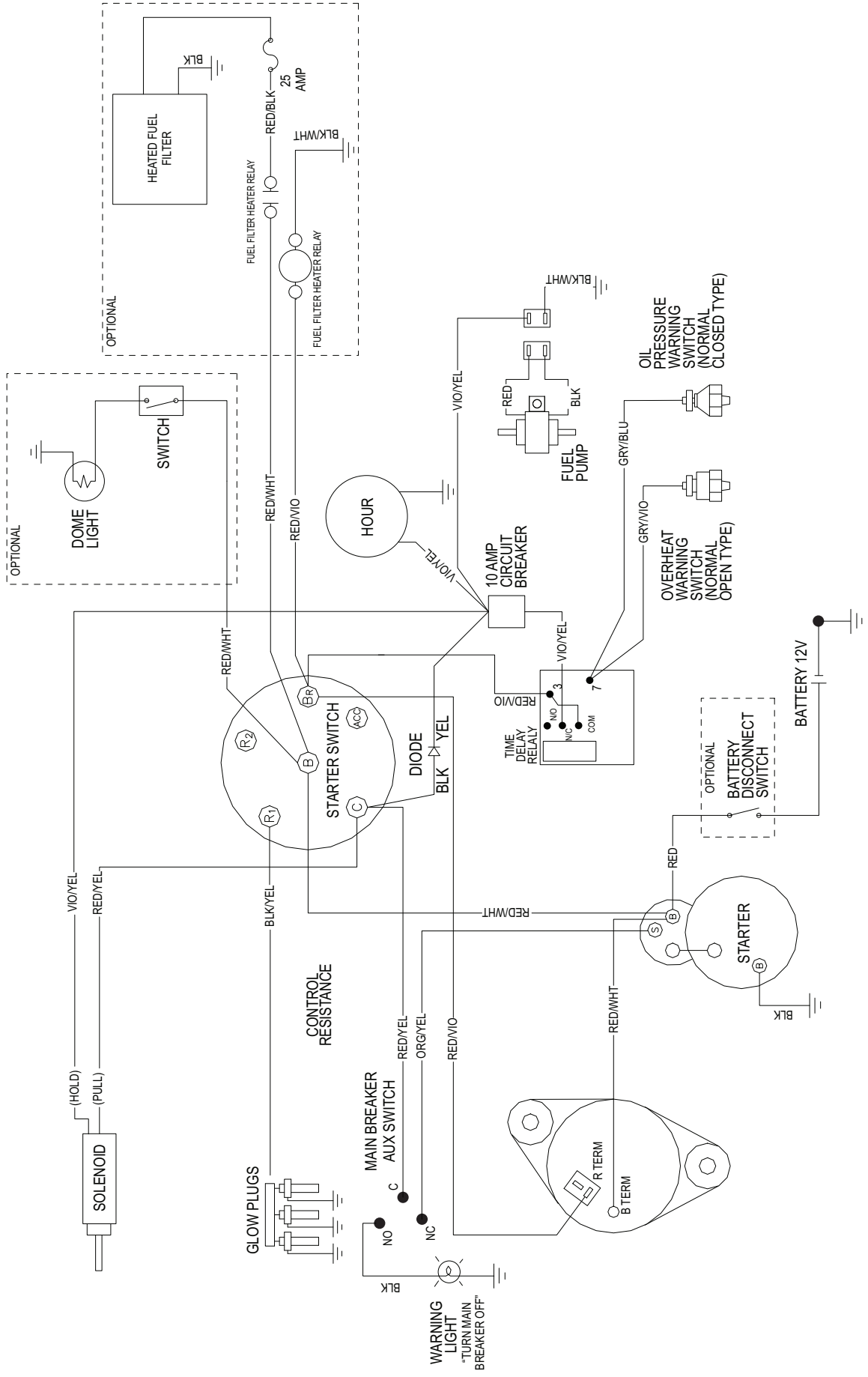

DC CIRCUIT WIRING DIAGRAM - DUAL ELECTRIC WINCH

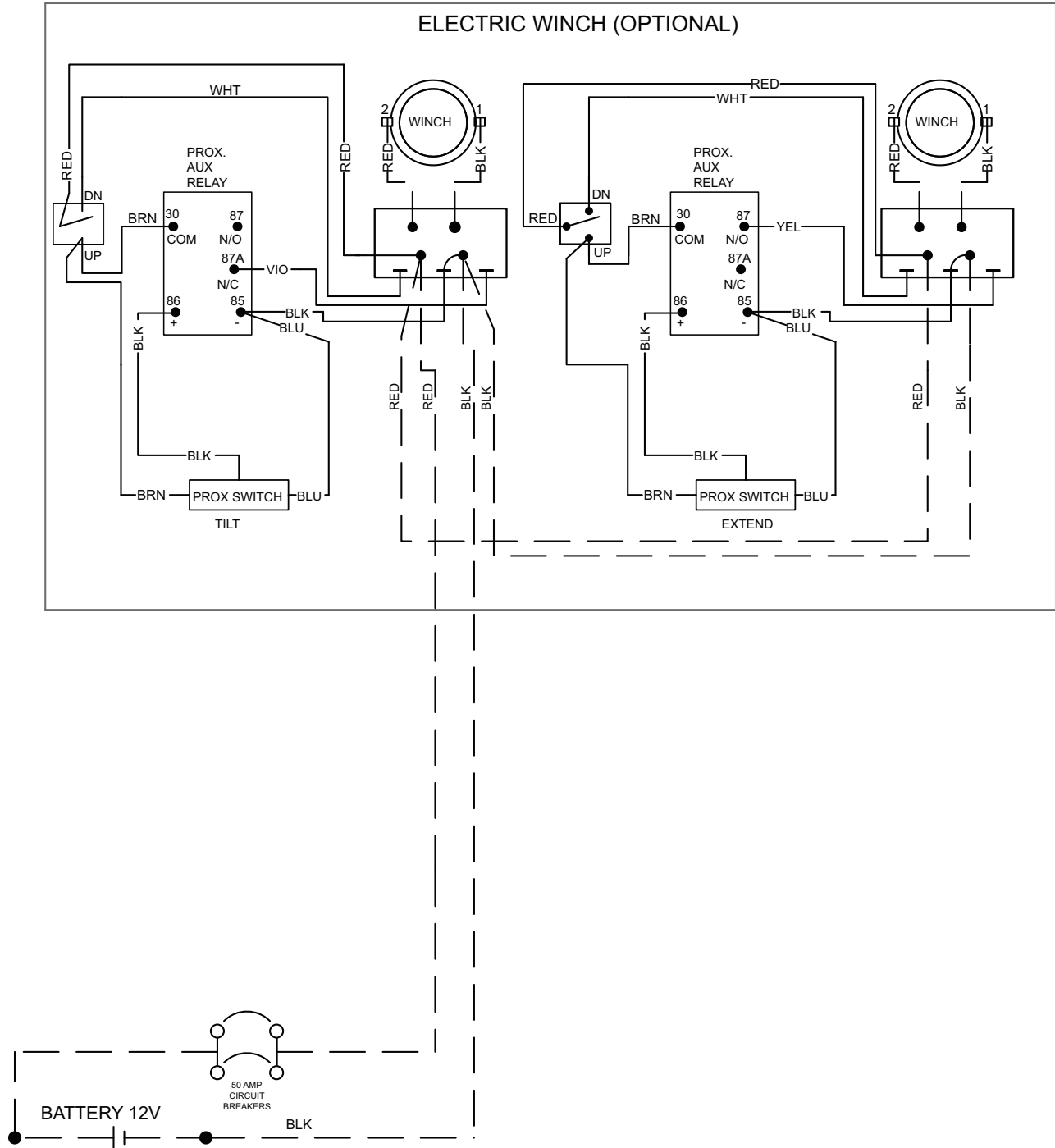

MAST JUNCTION BOX WIRING

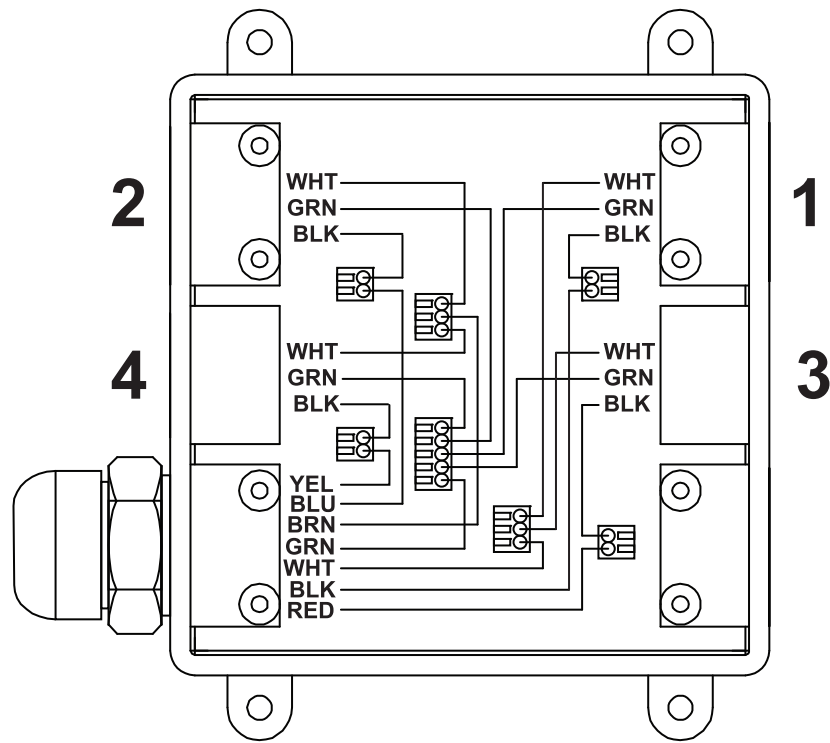

REV: W
PART NO: 11132
06.25.09